

# Technical Details & Assembly instructions



Mirror-inverted installation possible | Other color treatments available

## Item-Number

340 300, 340 301, 340 302, 340 303

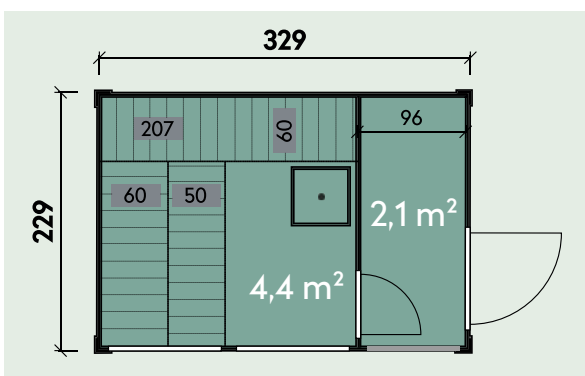

Being controlled by:

## Assembly Instructions

With this garden house you have chosen a quality product from Finnhaus-Vertrieb M. Wolff, and you made a good choice. These assembly instructions should help you in assembling the kit and give you one or another "tricky" detail, good advices and some tips.

**Each kit comes with individual drawings/Technical details from which you can find the respective dimensions and positions of the doors, windows and as well as the installation heights from the windows.**

Since we are also practitioners, we will save you from long texts, and concentrate on what is most necessary. You will find sufficient screws and fastening material in the delivery package, the selection is declared by itself by the respective needs.

### The following tools are required:

- ✓ Spirit level
- ✓ Mallet
- ✓ Rubber mallet
- ✓ Hitting block
- ✓ Tongs
- ✓ Tape measure
- ✓ Yard stick
- ✓ Drilling machine
- ✓ Cordless screwdriver
- ✓ Several bit tips
- ✓ Wood drill
- ✓ Carpet knife with hook blade
- ✓ Jigsaw
- ✓ Perhaps portable circular saw/Chop saw

### Beispiel



**WICHTIG / Important**  
for your records document

**SA 173581**  
Kontrollnummer / Control number



Take photos or cut out all labels on the package It contains all the important information that later may be needed for queries.

### Structural requirements

For the stability and durability of your house it is very important to build a professional foundation. The perfect assembly of the house is only guaranteed by an absolute horizontal and load-bearing foundation.

If you have any questions about the foundation which is essential for your house, it is best to contact a local specialist who is familiar with the requirements and soil structures of your region.



**Compacted ballast bed with paving slabs is the minimum foundation to build a house.**

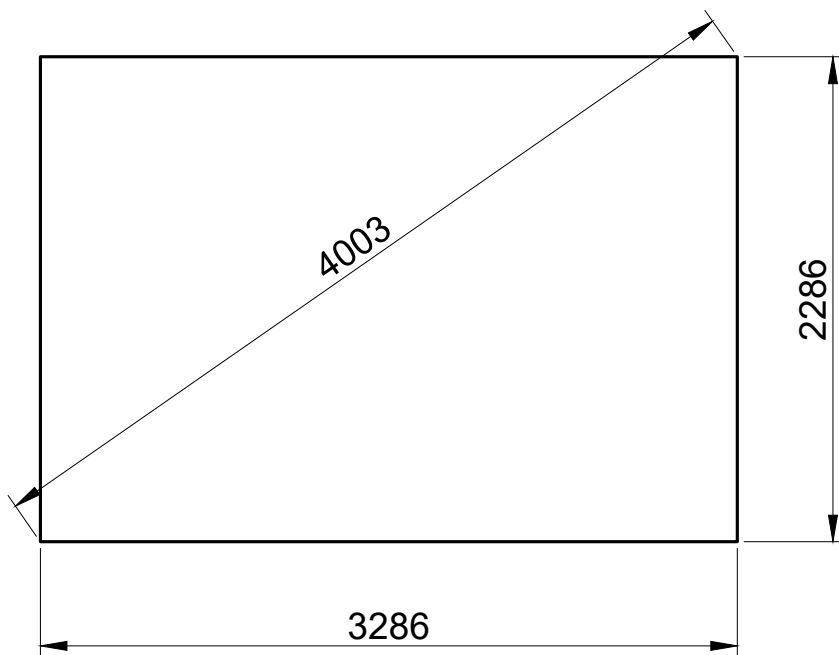
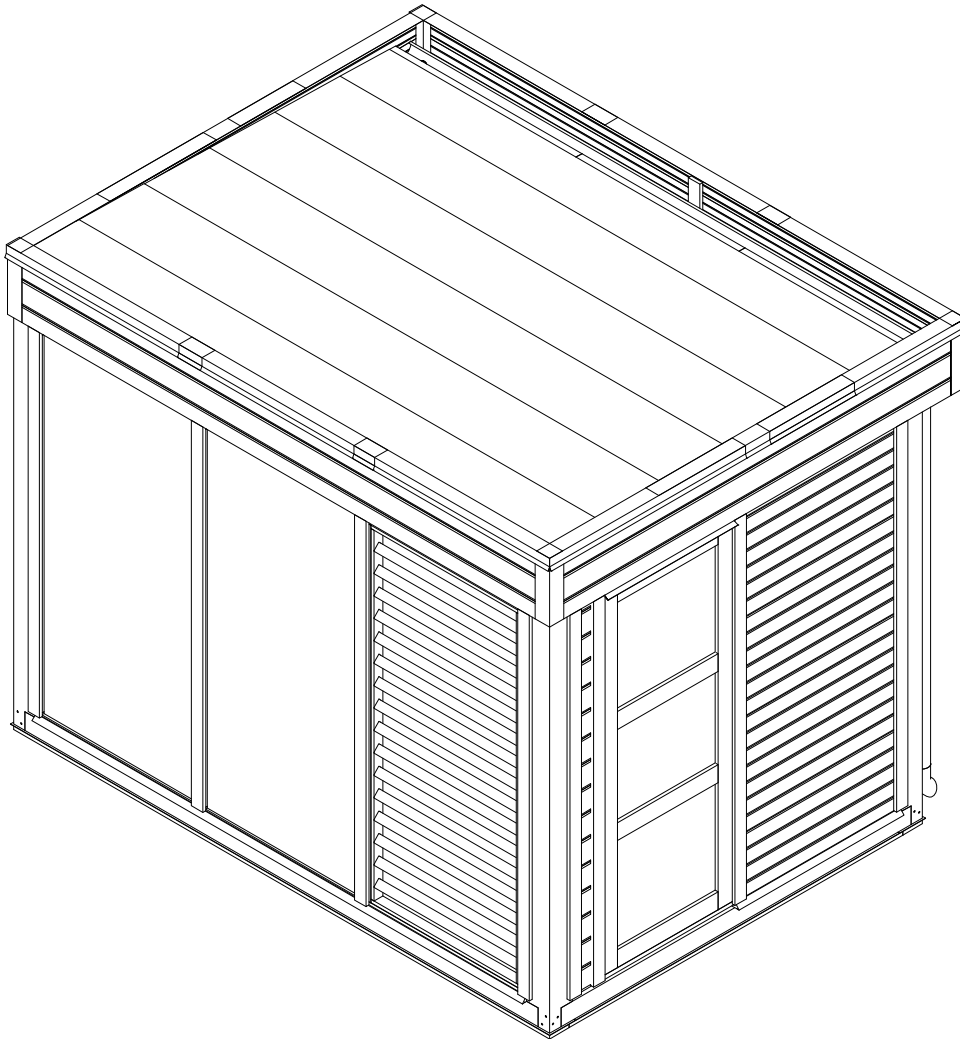

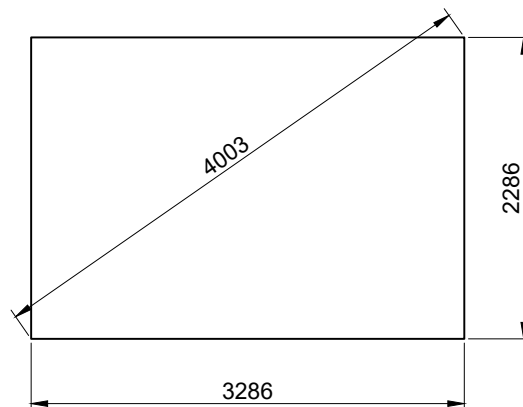
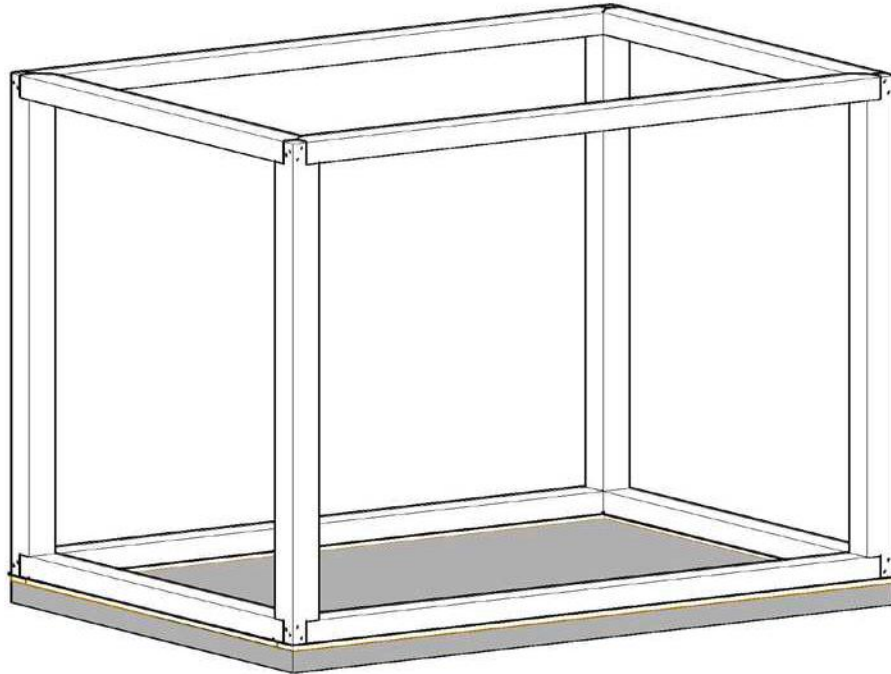

## FUNDAMENT

Es ist sehr wichtig, eine gute Grundlage zu haben. Daher empfehlen wir, das Fundament nach den hier vorliegenden Skizzen herzustellen.

Zunächst muss das Fundament entsprechend der Landschaft und den Bodenverhältnissen vorbereitet werden. Das Fundament muss waagrecht und rechtwinklig sein.

Es muss sichergestellt sein, dass es seine Eigenschaften nicht verändert.













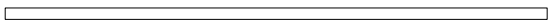







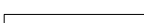





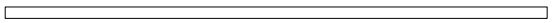











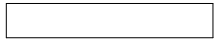

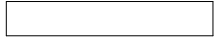

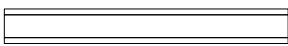

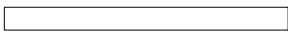

Wir empfehlen die Verwendung von Betonfundamenten. Wenden Sie sich an einen qualifizierten Bauherrn vor Ort oder einen Ingenieur, um ein geeignetes Fundament vorzubereiten, das zu Ihrem Standort passt.

Durch unsachgemäße Fundamente können Risse in den Konstruktionen auftreten. Aufgrund ungleichmäßiger Fundament kann sich die geometrische Form des Produkts ändern, was zu einer Verdrehung der Tür/Fenster führen kann, und/oder zu einem Spalt. Und im schlimmsten Fall bricht das Produkt zusammen.

Wenn Sie der Empfehlung nicht folgen, verliert das Produkt seine Garantie.

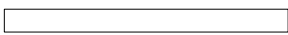









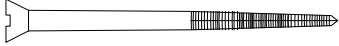
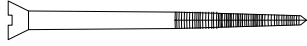







Nr.	Detail		Pcs.	Measures
(L) (R)			2	100x140x2146
(B) (F)			2	100x140x3146
(S)			4	140x140x2305
(L) (R)			2	100x140x2146
(B) (F)			2	100x140x3146
(4)			2	1143x2285
(4a)			1	1000x2285
(10)			2	18x70x2100
(1)			4	28x45x3004
(2)			8	28x45x2015
(3)			4	28x45x2004
(a)			20	45x45x80
(b)			5	123x60x2003
46 OSB			6	9x460x2003
(DF)		Diffusion film 5,5 m	2	1,5x4m
(IW)		Isolation 50 mm	9 sheets	50x600x1200
(SF)		Steam foil 4,5 m	1	3x3,5m
(6)			15	28x145x3075



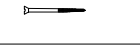
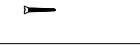

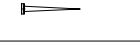

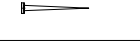
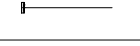

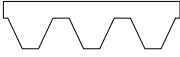
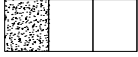
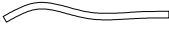

Nr.	Detail		Pcs.	Measures
D			1	75x850x2100
D1			1	75x150x2100
Ws			6	75x998x2100
Ww			2	75x998x2100
WB			1	75x998x2100
5			6	10x15x2700
7		inside	7	18x70x2015
		outside	15	18x70x2047
F1			1	28x45x3003
F2			1	18x95x3322
F3			1	18x145x3322
F4			1	18x145x3322
F7			4	28x45x1000
L1			1	28x45x2003
L2			1	18x95x2512
L3			1	18x145x2512
L4			1	18x145x2512
L7			3	28x45x1000
R1			1+1	28x45x1003 28x45x150
R2			1	18x95x2512
R3			1	18x145x2512
R4			1	18x145x2512
R7			3	28x45x1000

Nr.	Detail		Pcs.	Measures
B1			1	28x45x3003
B2			1	18x135x3322
B3			1	18x110x3322
B4			1	18x70x220
B5			1	18x70x205
B6			1	18x70x300
B7			3	28x45x1000
B8			2	45x45x365
B9			1	18x95x3322
B10			1	18x100x3395
B11			1	18x145x3322
B12			1	18x145x3322
Sk1			10	0.5x88x1200
Sk2			4	0.5x80x365
Sk3			1	0.5x185x800
Sk4			2	0.5x88x625
7.1			4	18x30x2100
7.2			2	106x95x2160
7.3			6	18x70x2115
Ws <sub>3</sub>			1	70x998x2175 inside
D <sub>D</sub>			1	70x998x2175
8			2	18x70x795
			2	18x70x1825
			2	18x70x1825



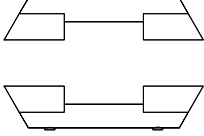
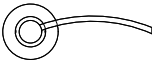
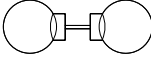

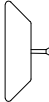
Nr.	Detail	Pcs.	Measures
A0		38	Ø8x200
A1		8	Ø6x180
A2		—	Ø6x150
A3		20	Ø5x100
A4		118	Ø6x80
A5		90	Ø4x70
A6		—	Ø4x70 galvanized
A7		4	Ø4x60
A8		693	Ø4x50 galvanized
A9		34	Ø3.5x45
A10		—	Ø4x35 galvanized
A11		9	Ø3.5x35 galvanized
A12		—	Ø3.5x30
A13		—	Ø3x30
A14		—	Ø3x15
A15		—	Ø4x15
A16		—	Ø5x30
A17		1 Pack.	Ø2x20
A18		—	Ø2.8x30
A19		—	Ø2x25
A20		1 Pack.	Ø1.2x31
A21		147	Ø4.8x28

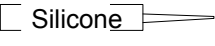
Nr.	Detail		Piece
S1		—	
S2		—	
S3		—	
S4		—	
S5		—	
S6		—	
S7			
S8		—	
○			
T1		—	
T2		1	
T3		1	
T4		1	
T5			
T6			
T7		—	

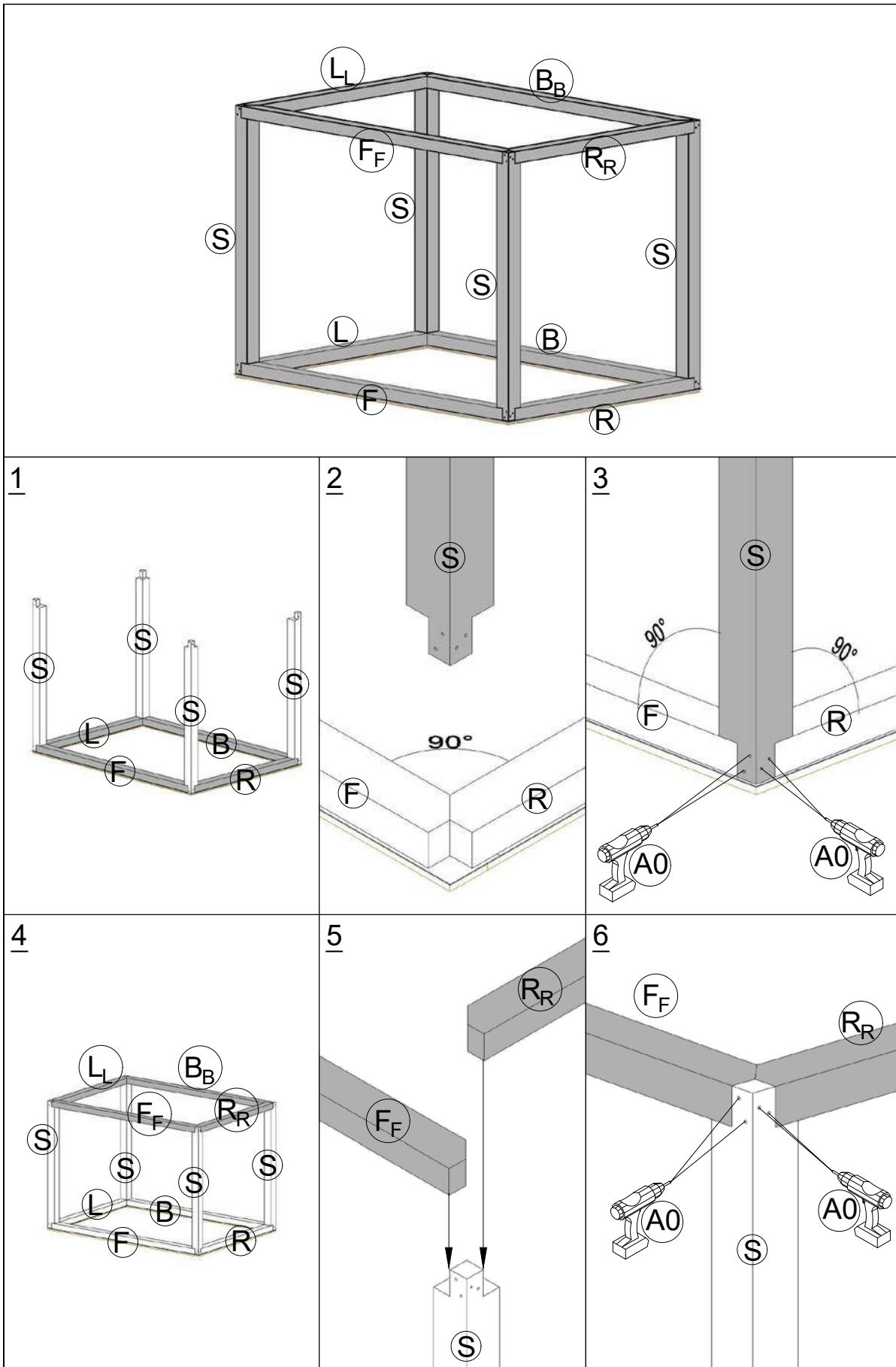

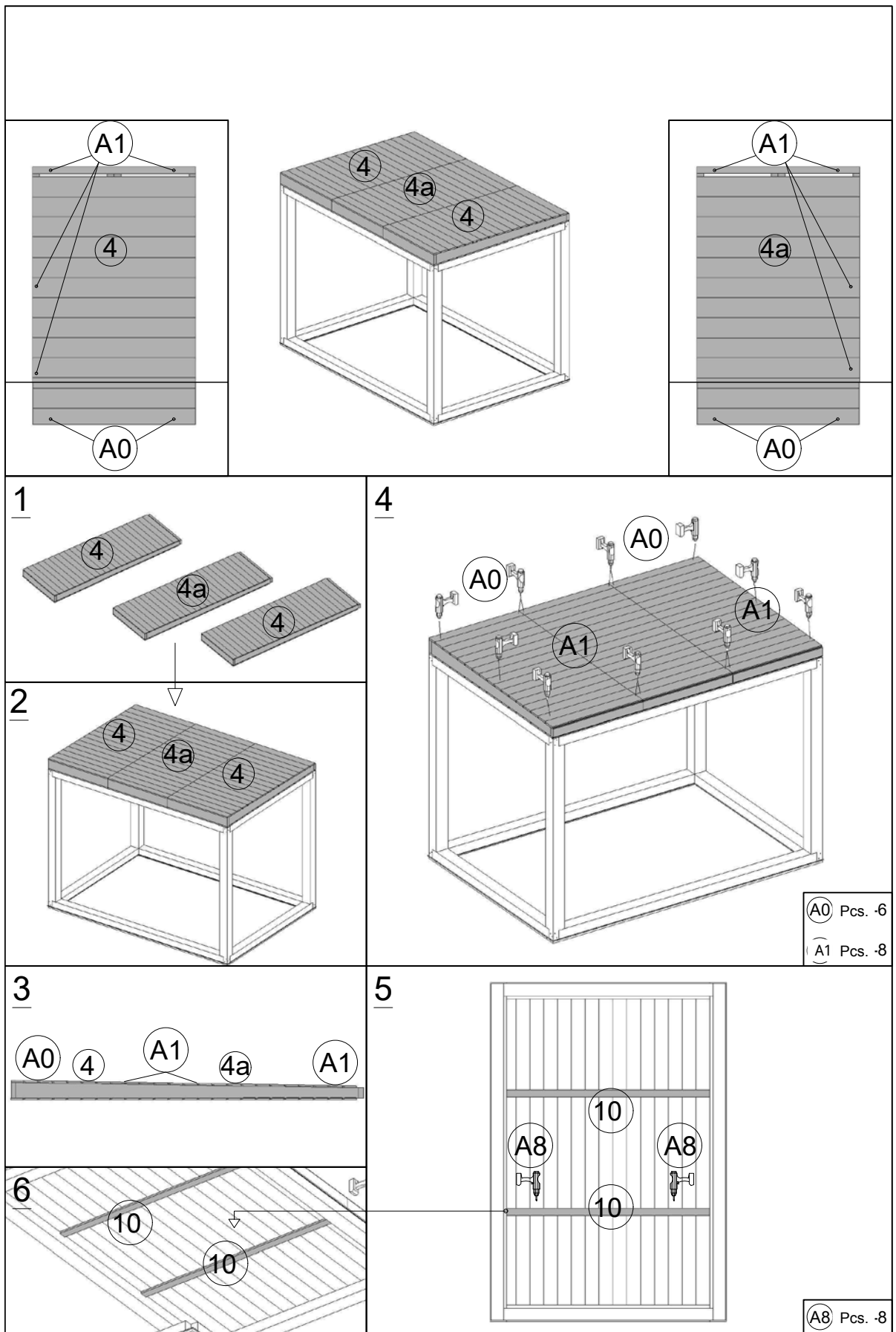

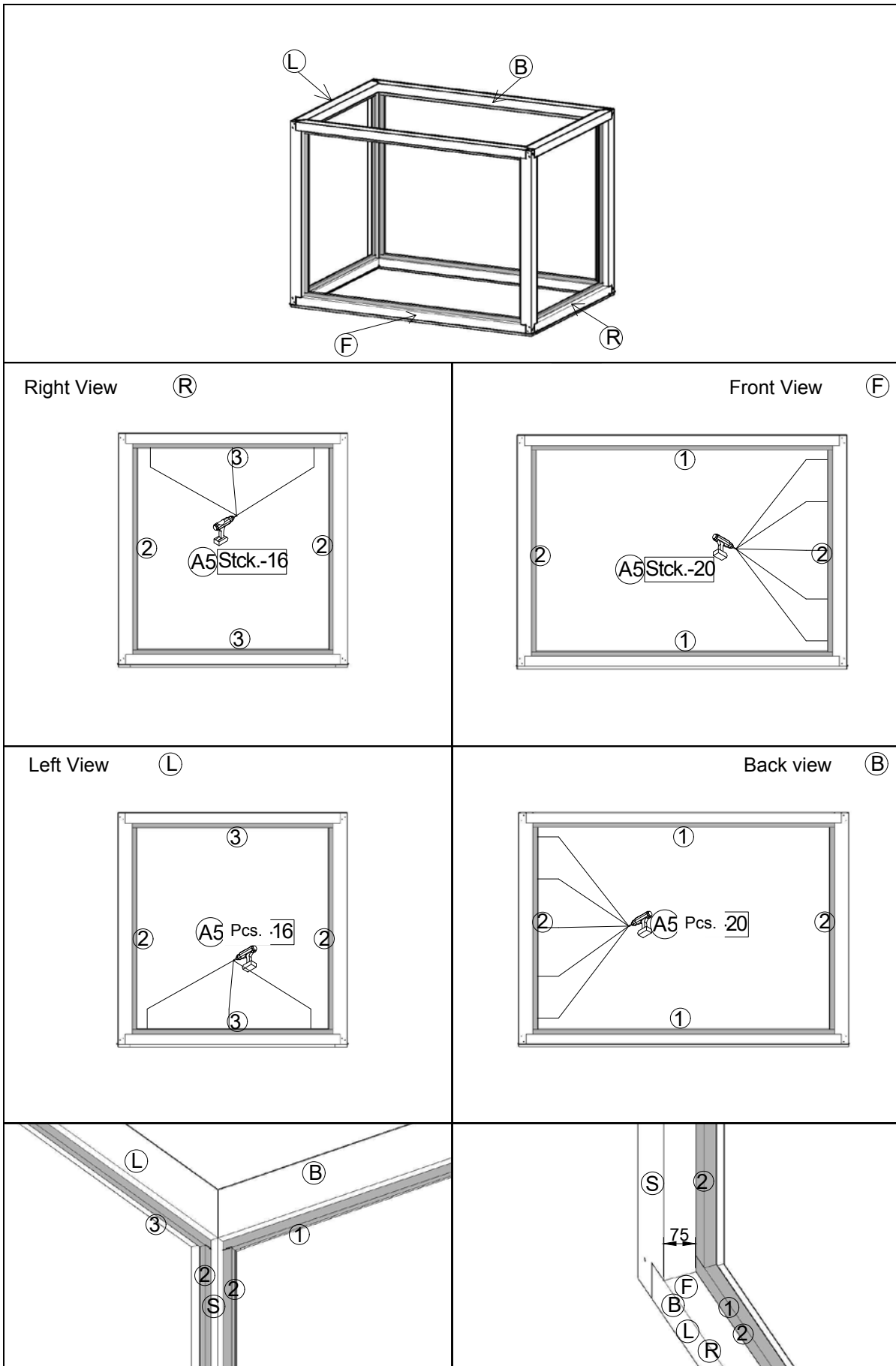

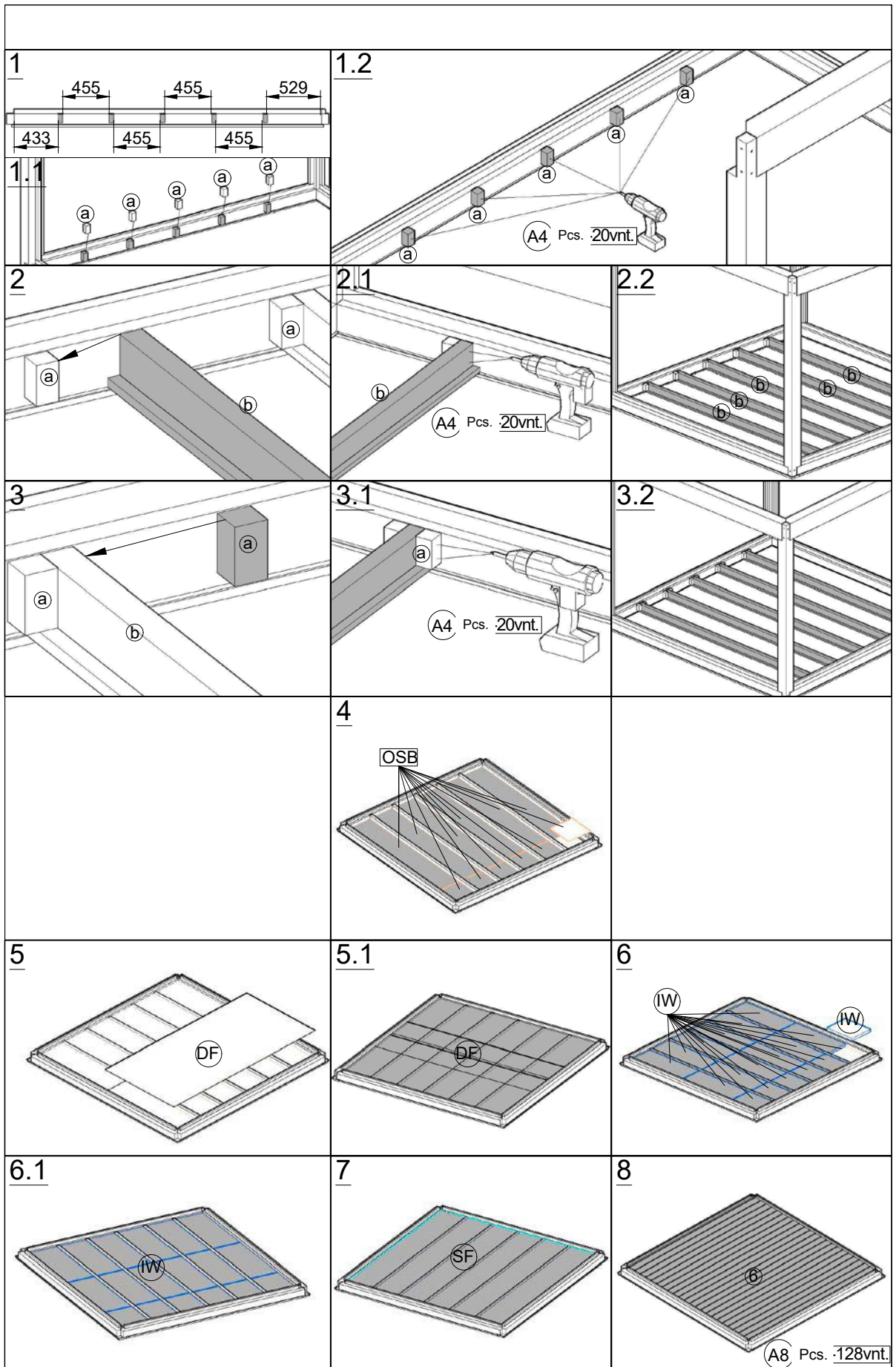

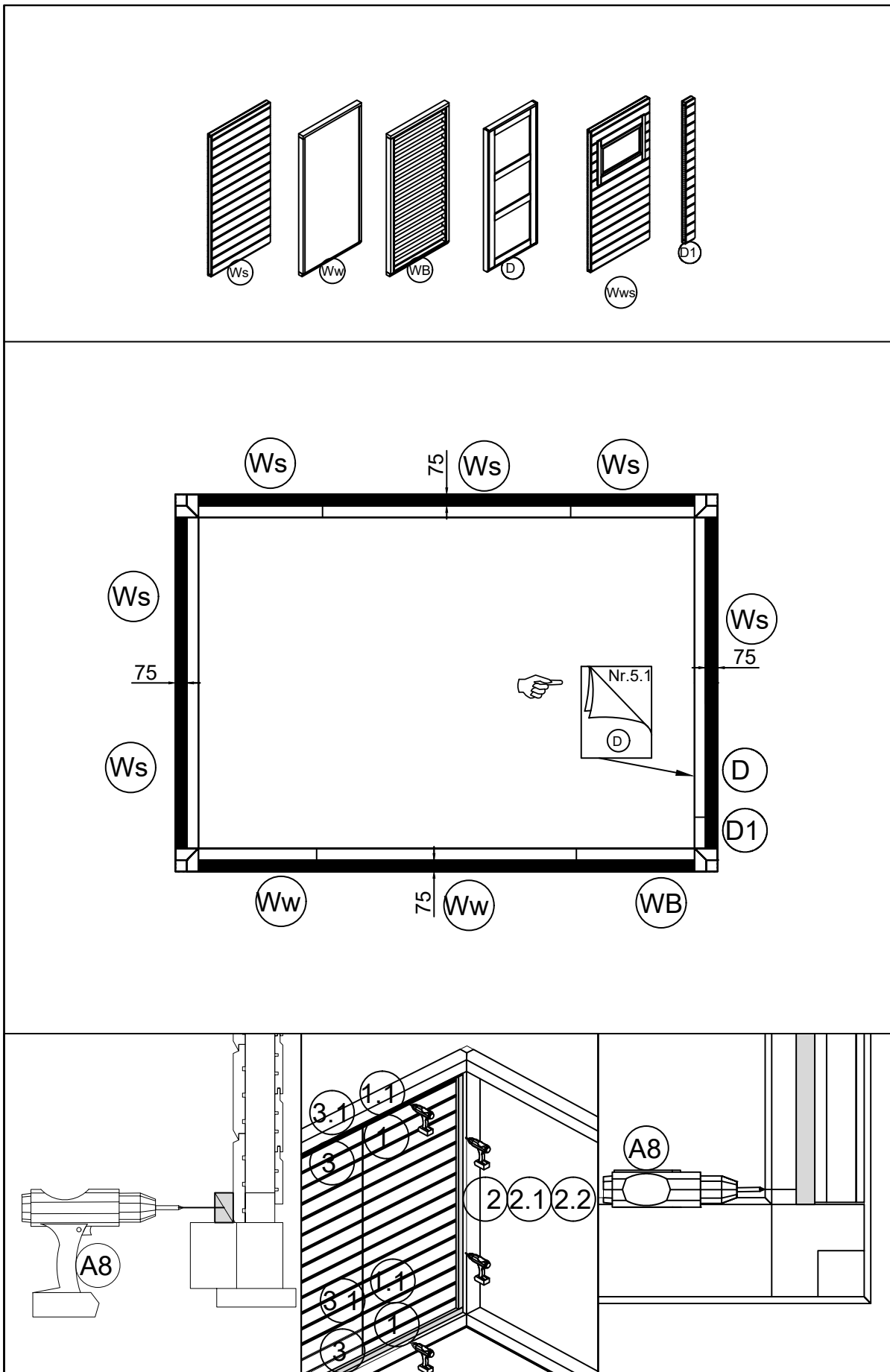

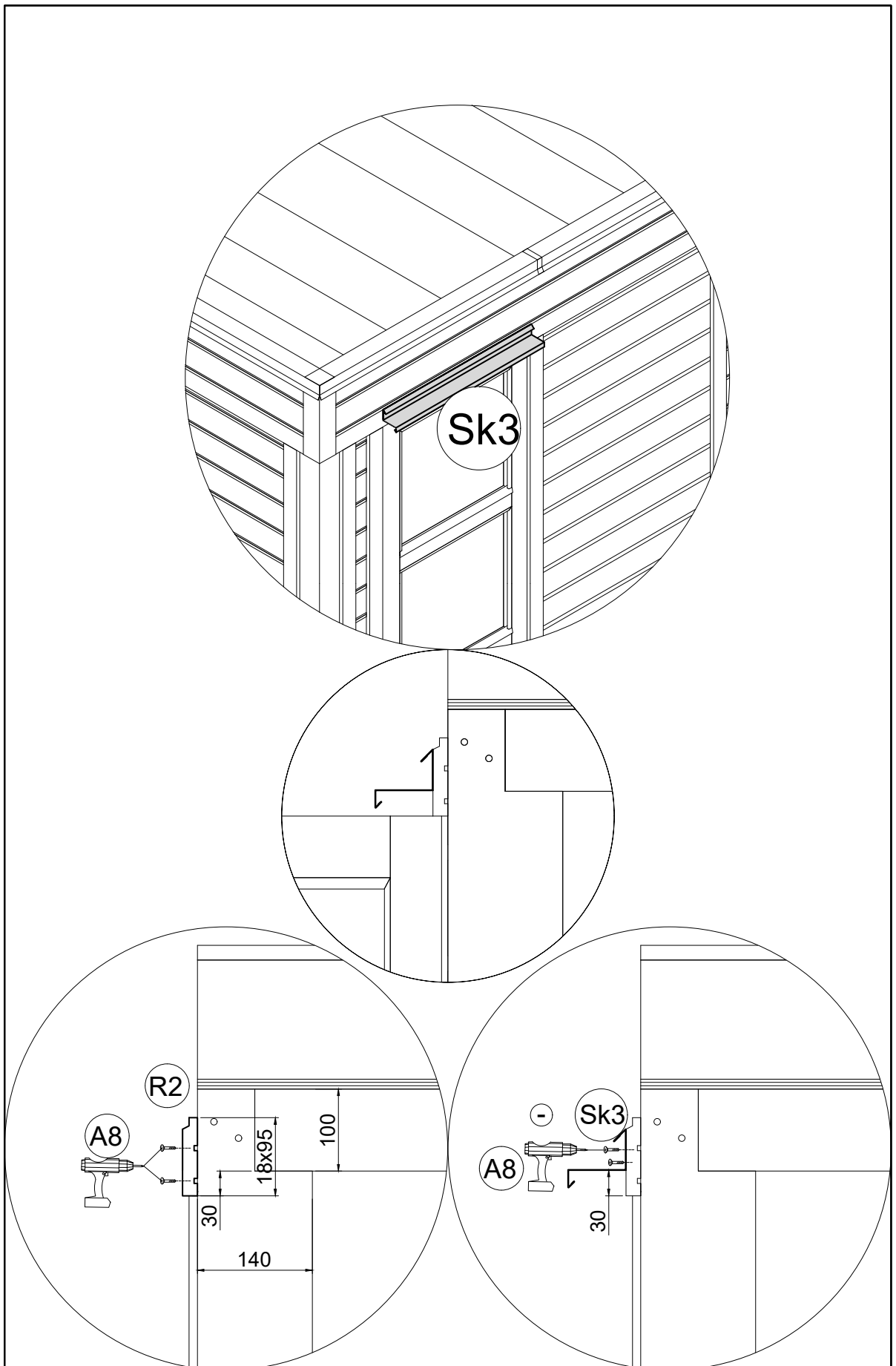



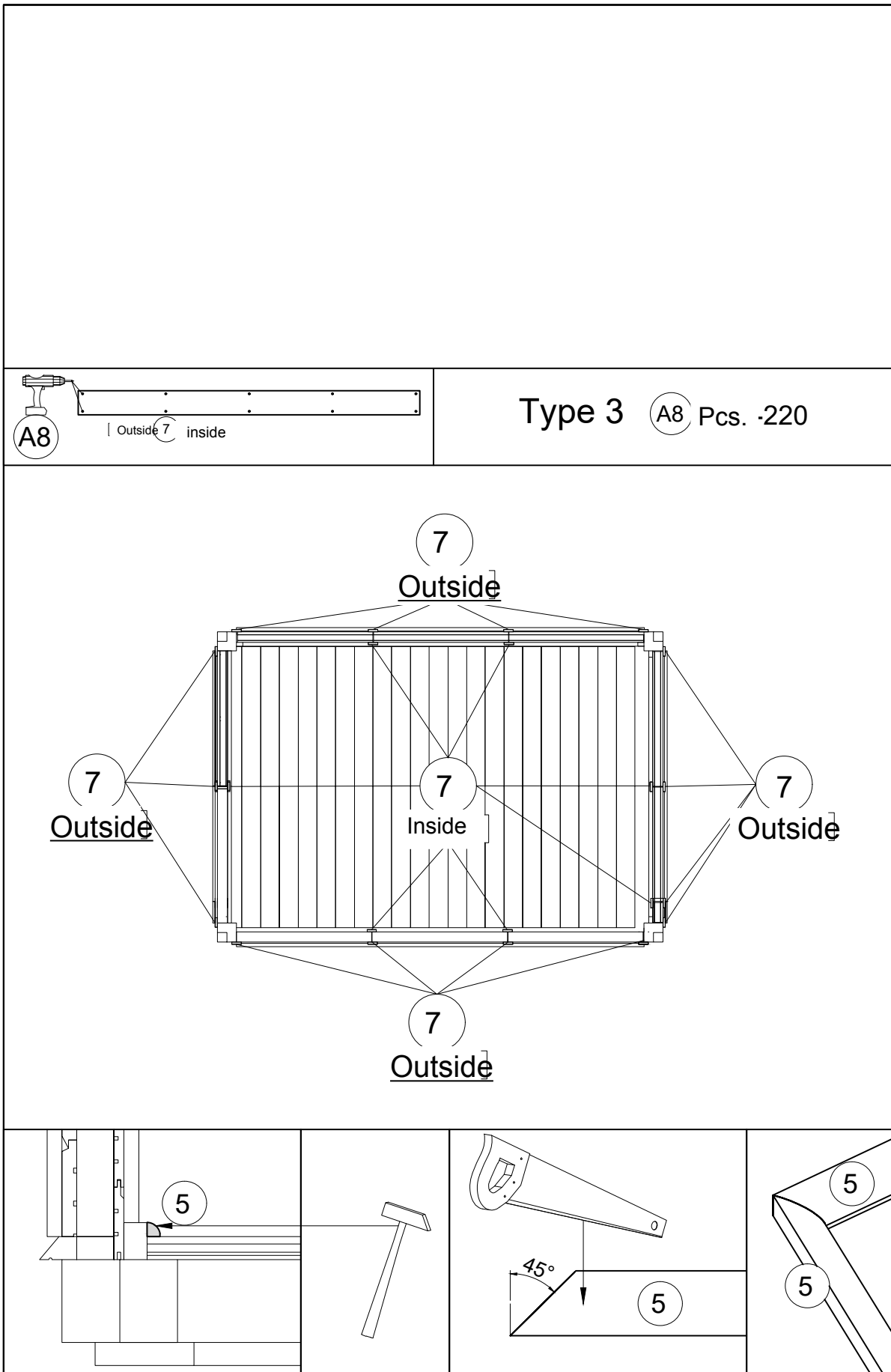

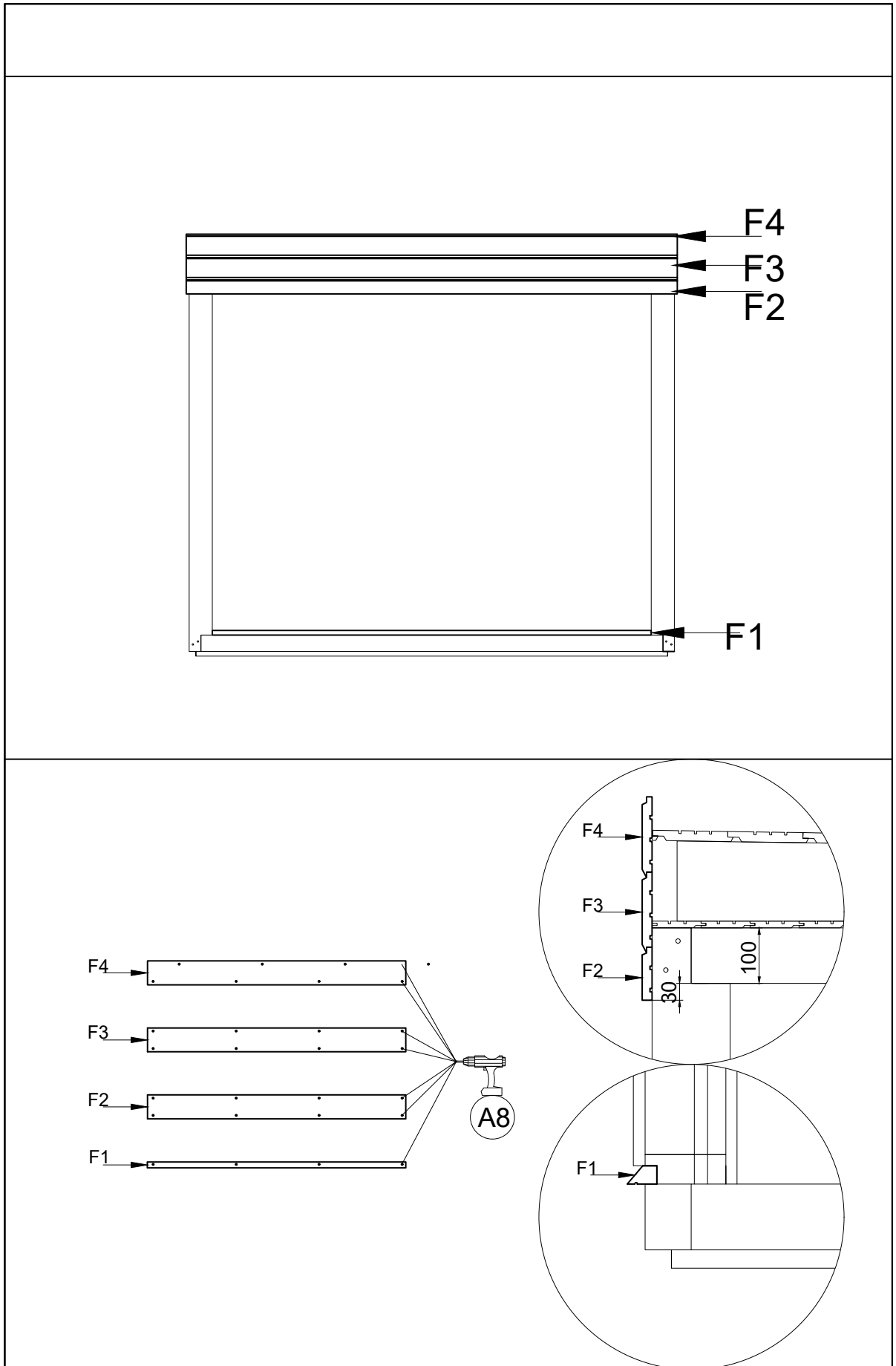

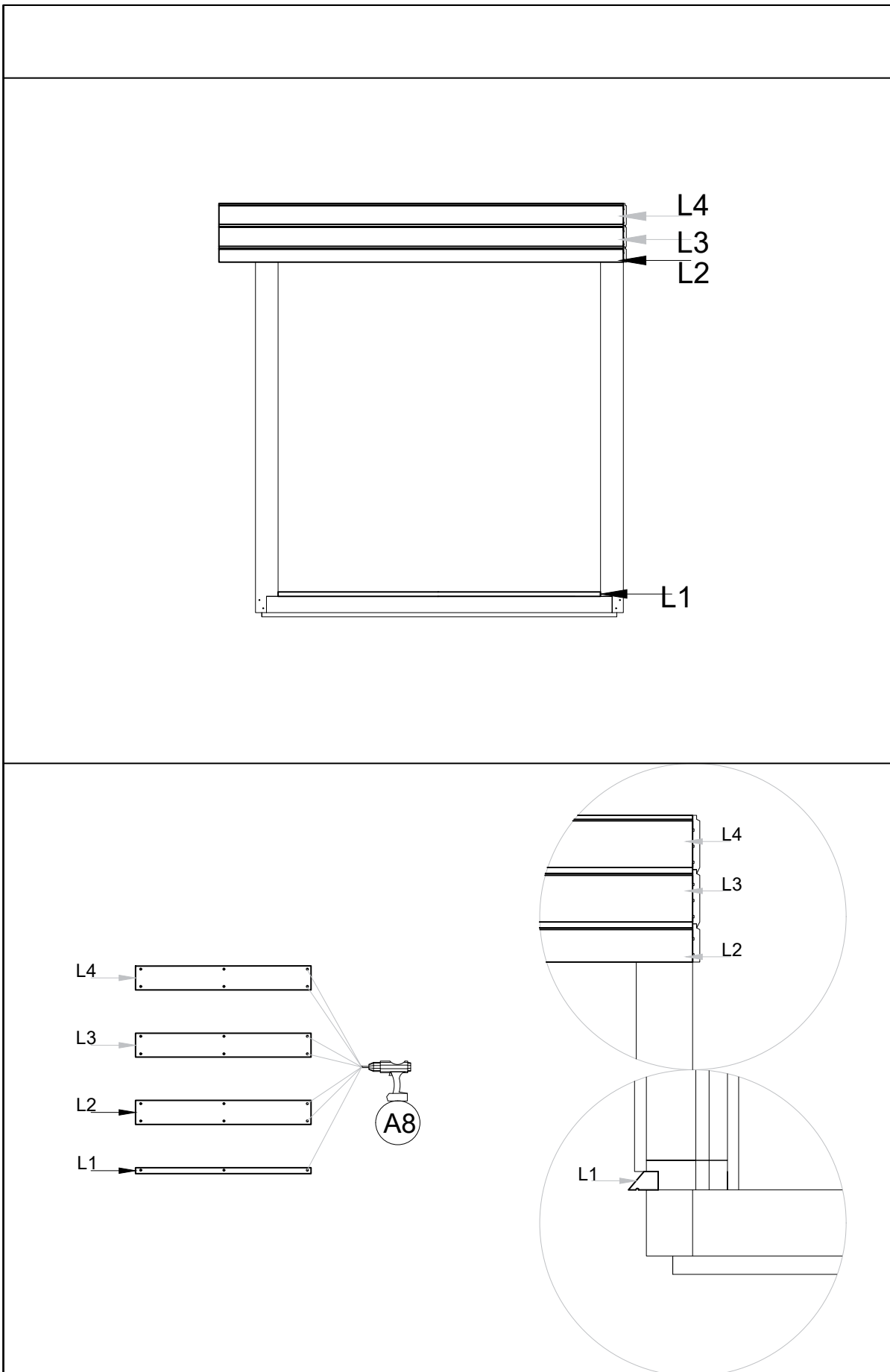

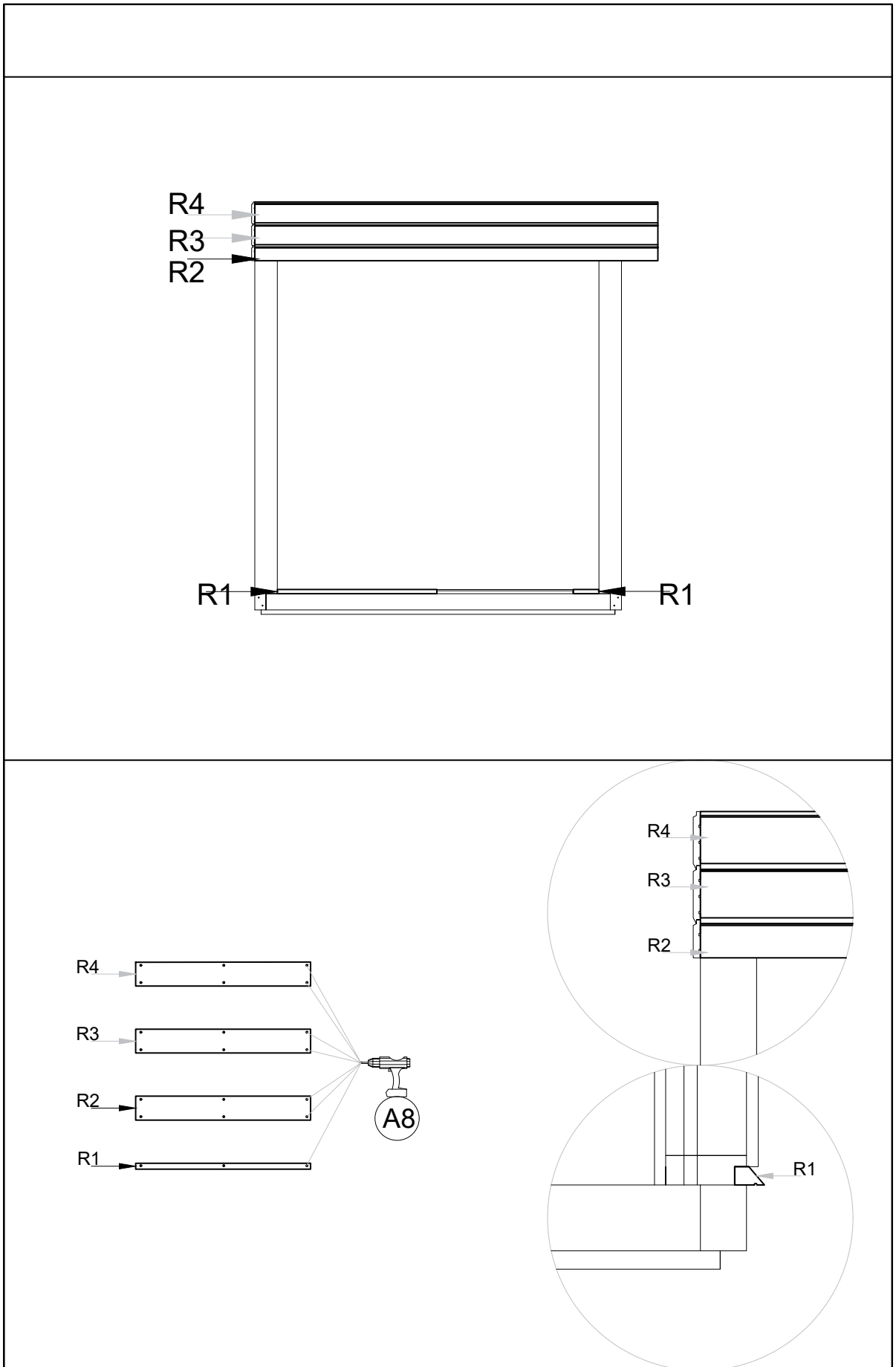

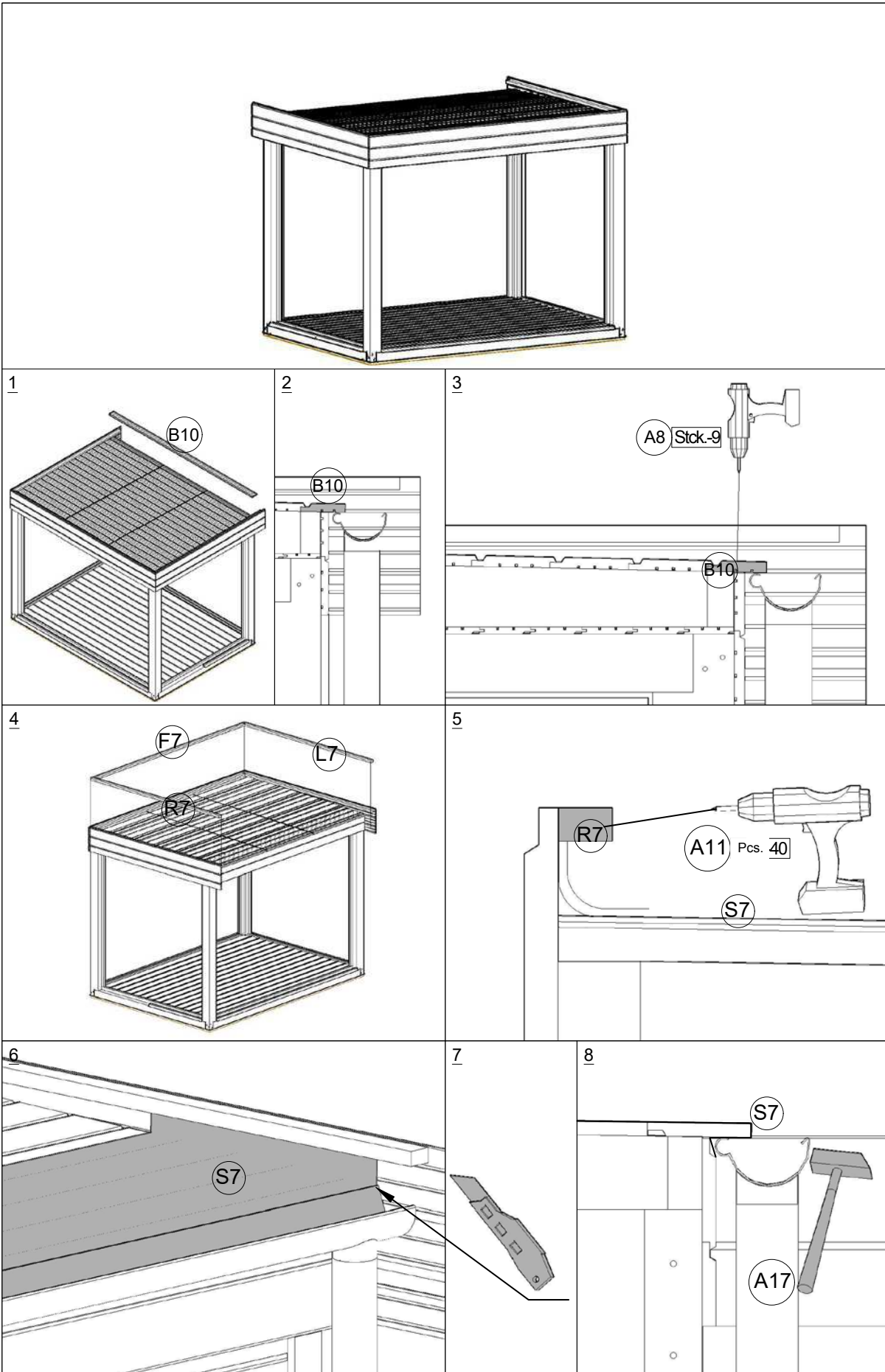

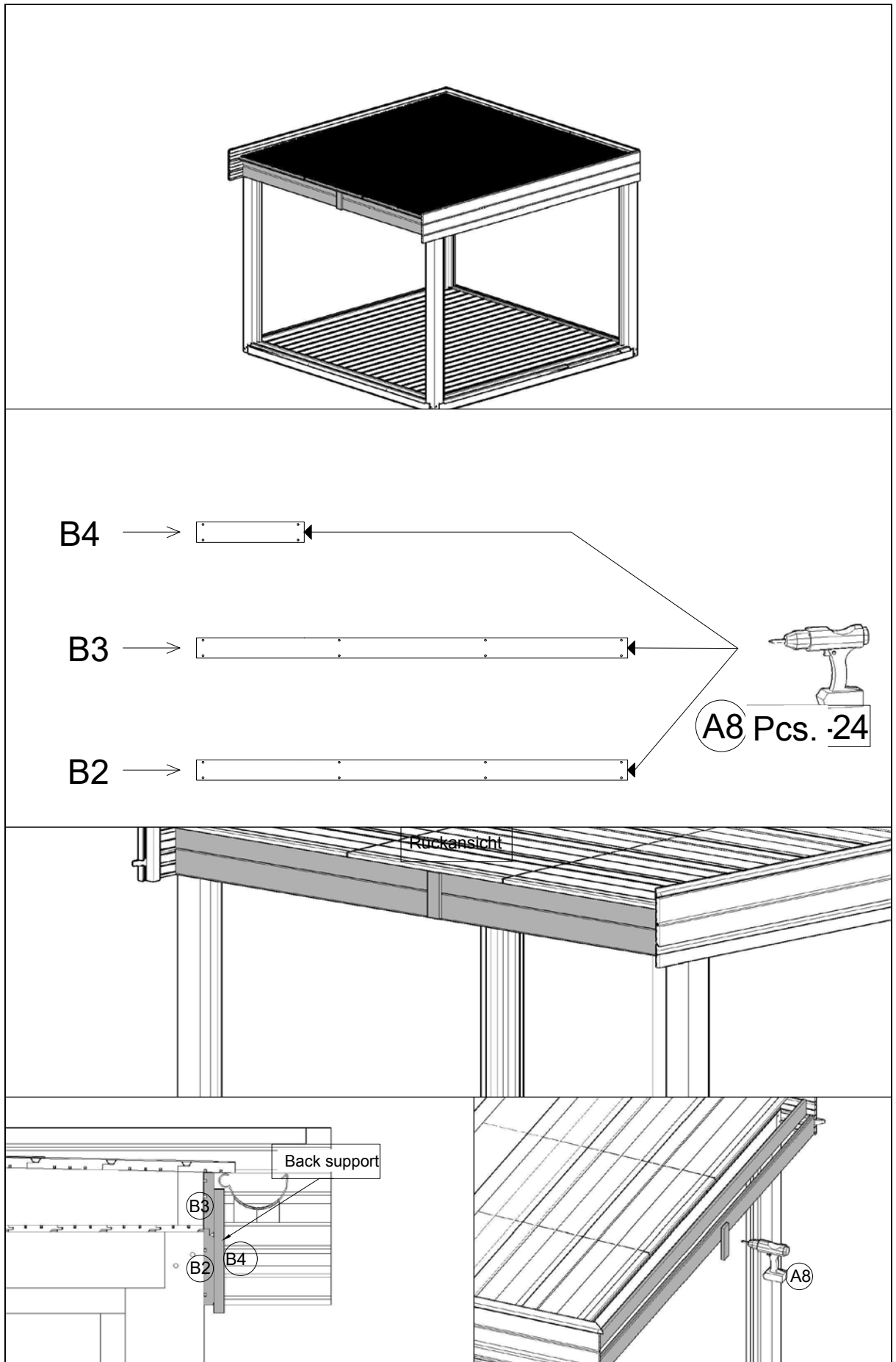

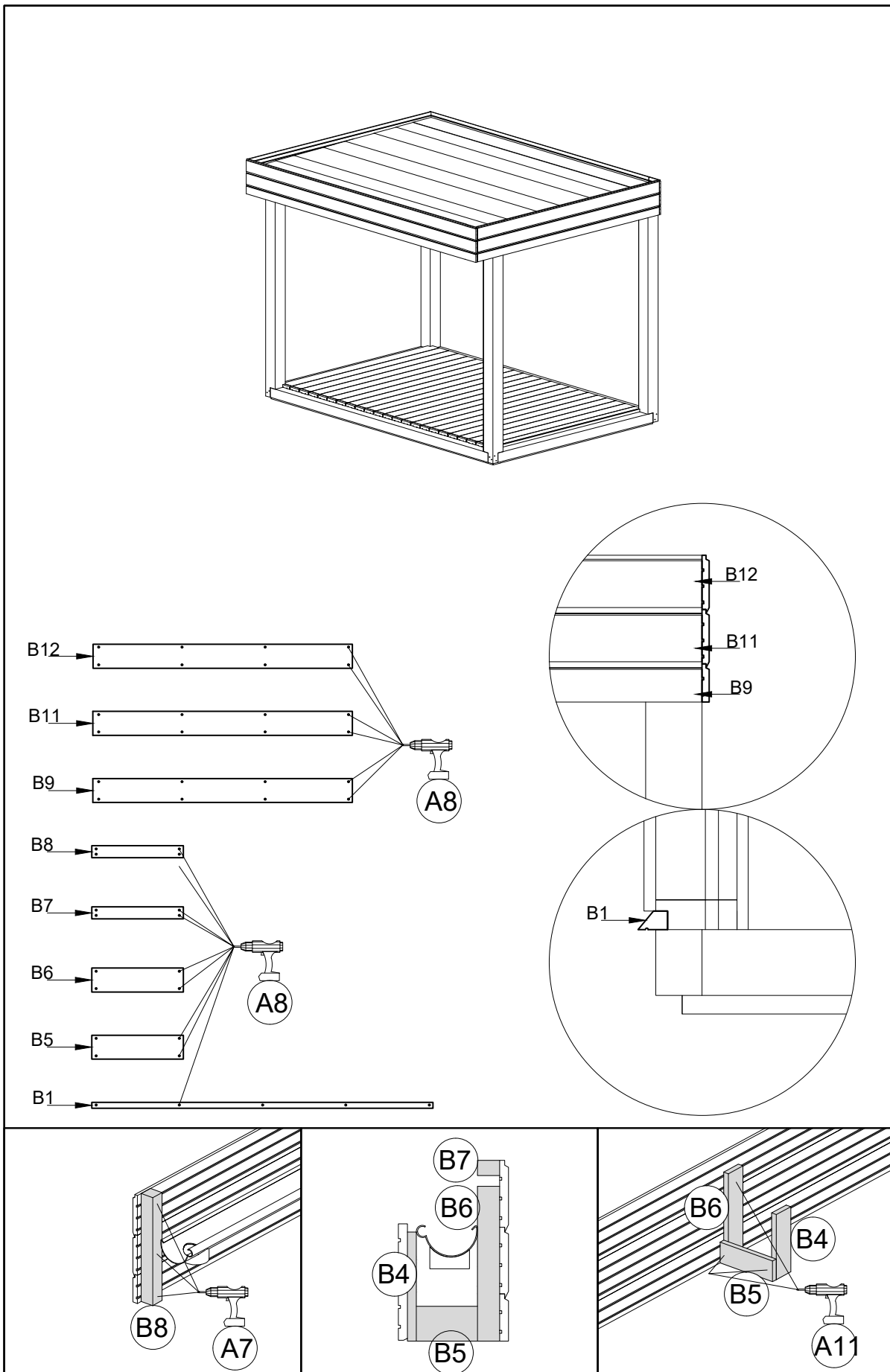

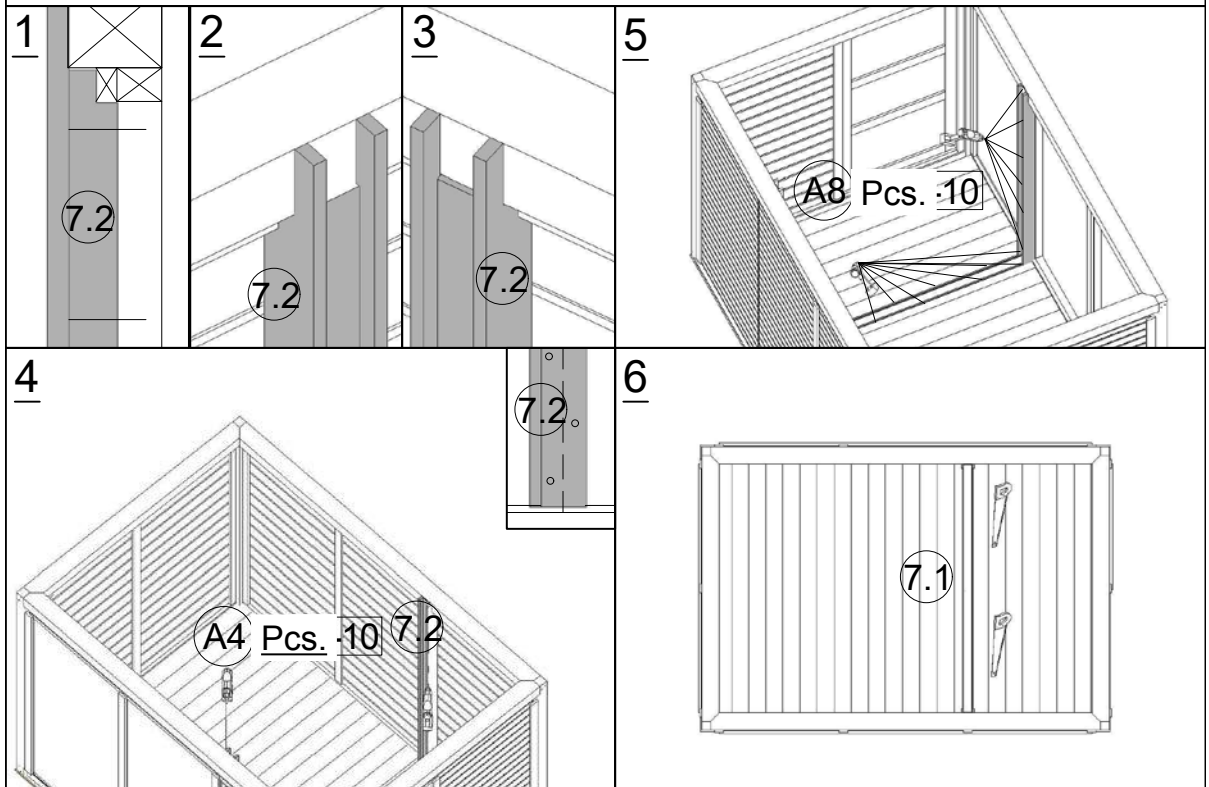
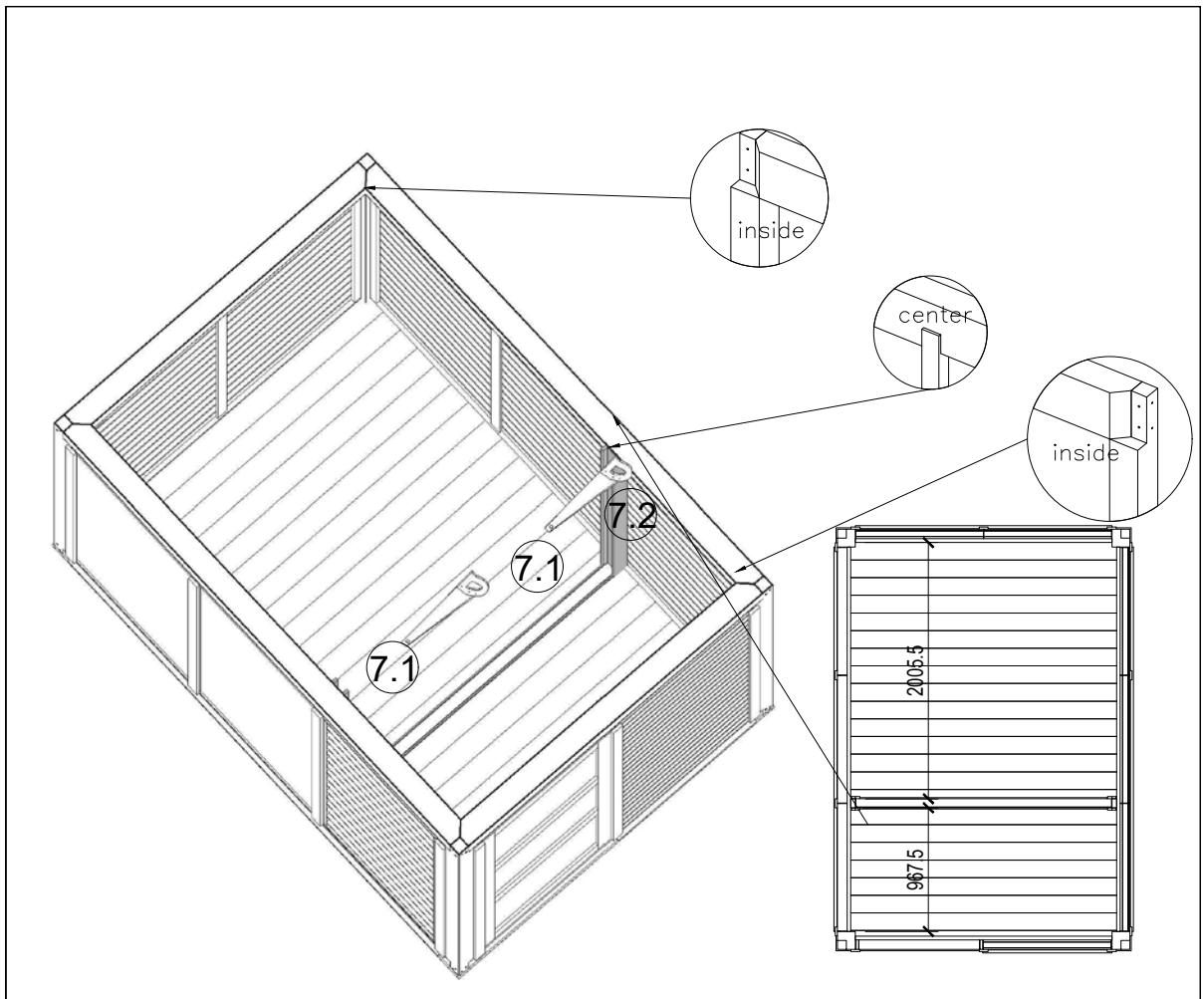



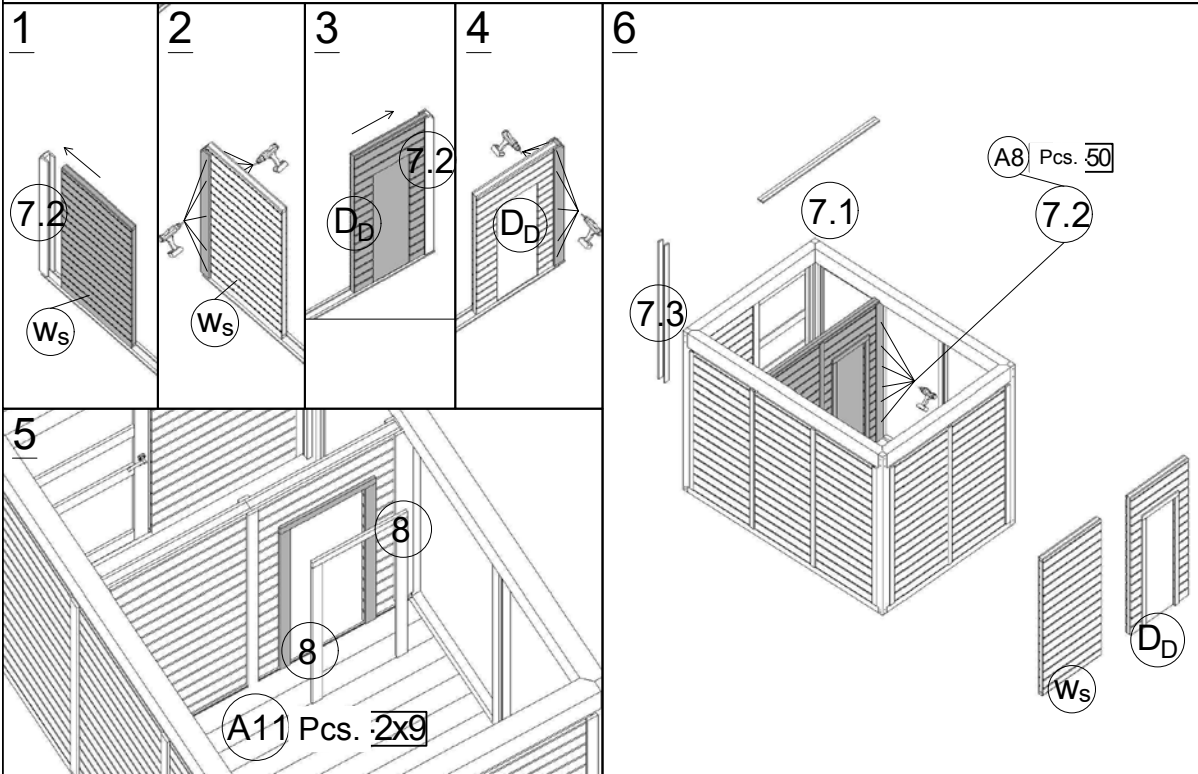
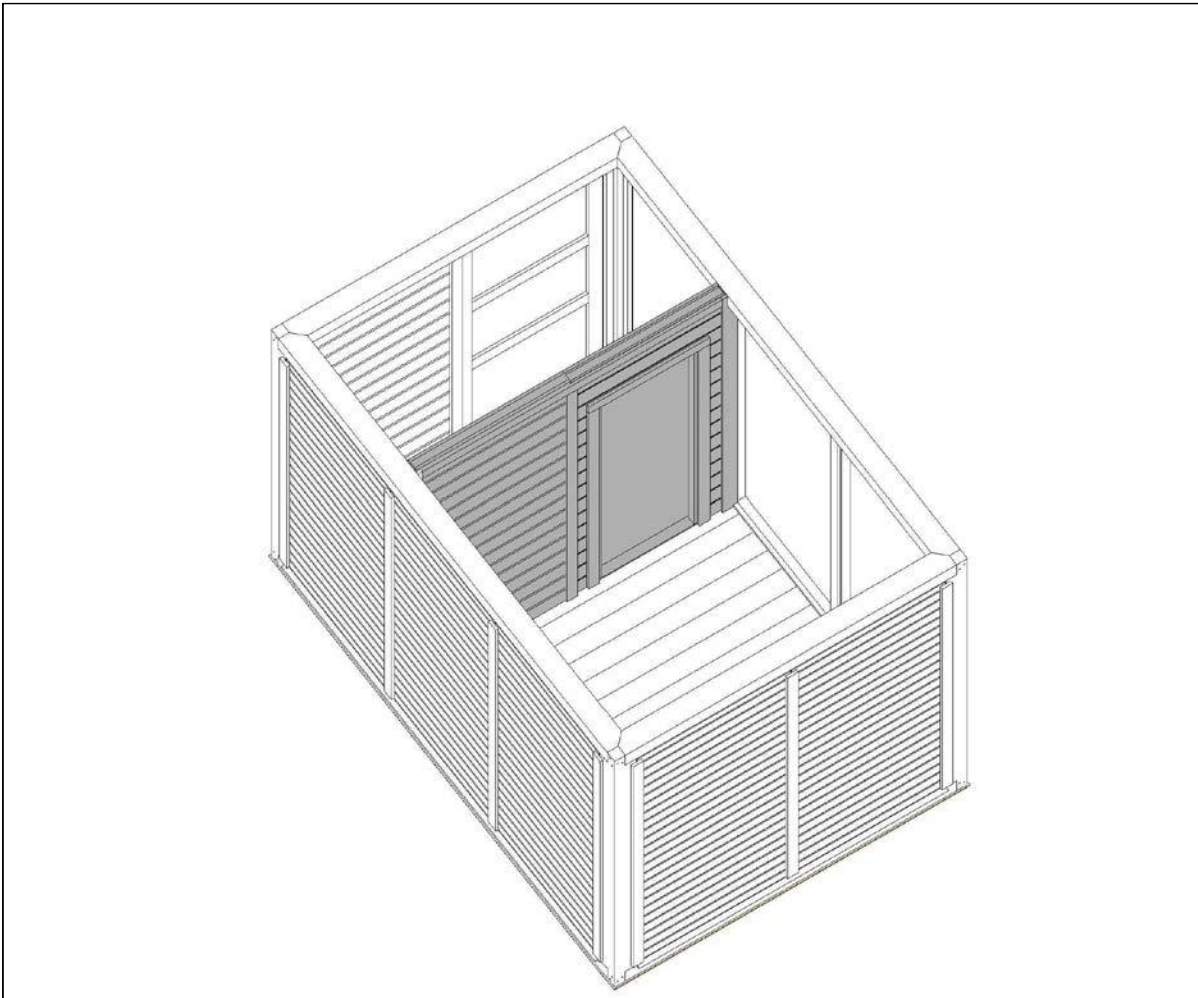

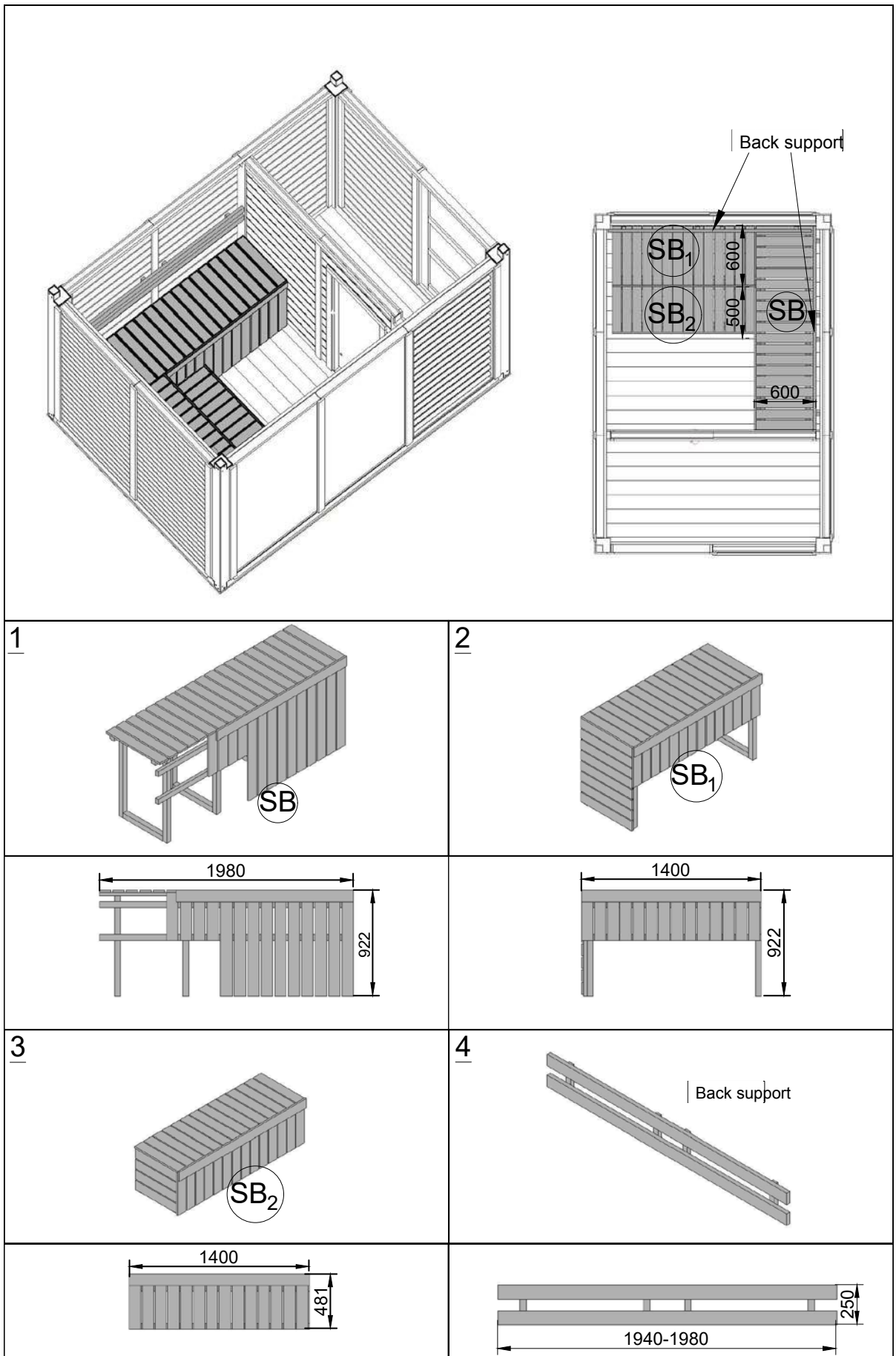

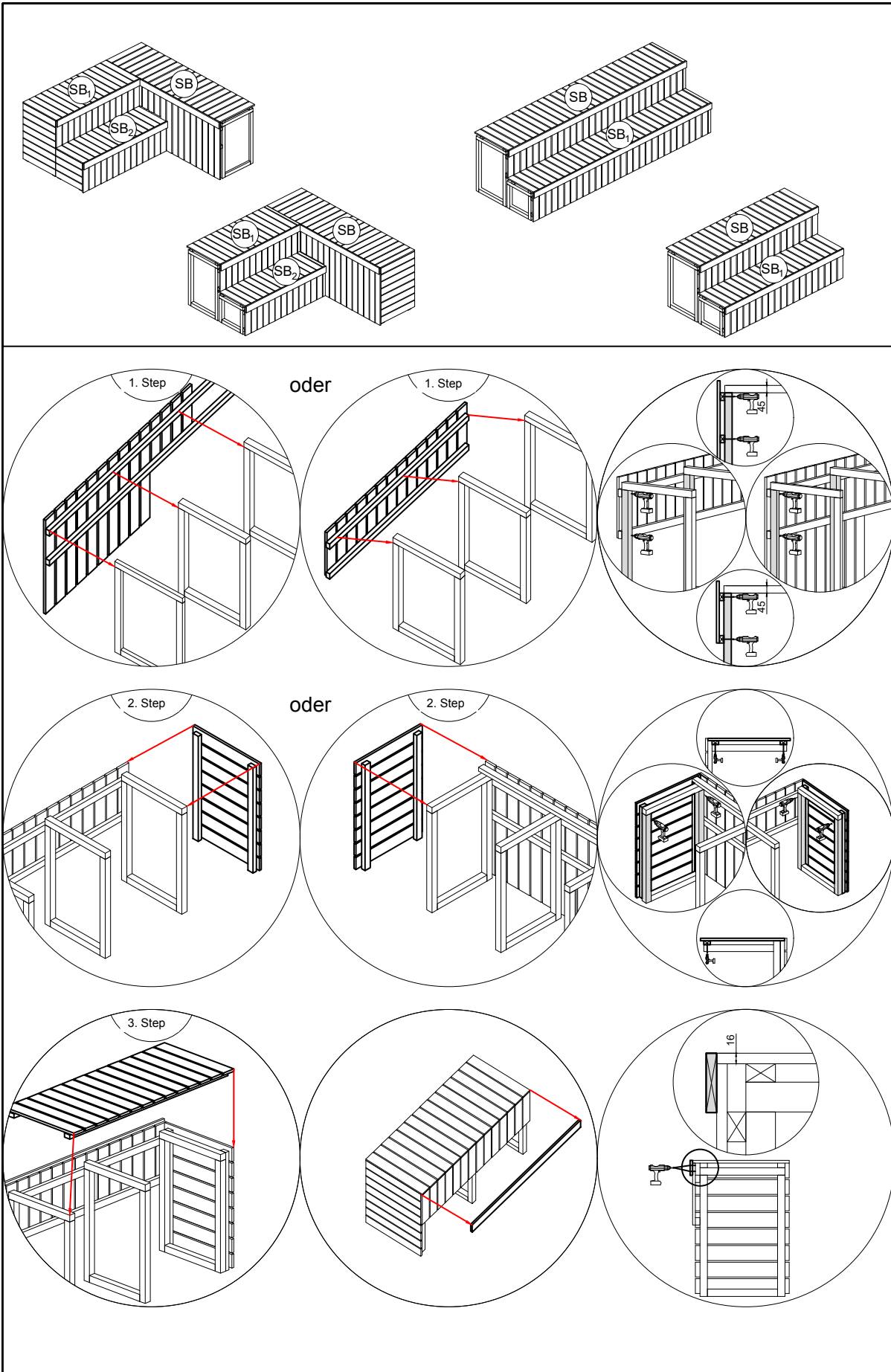

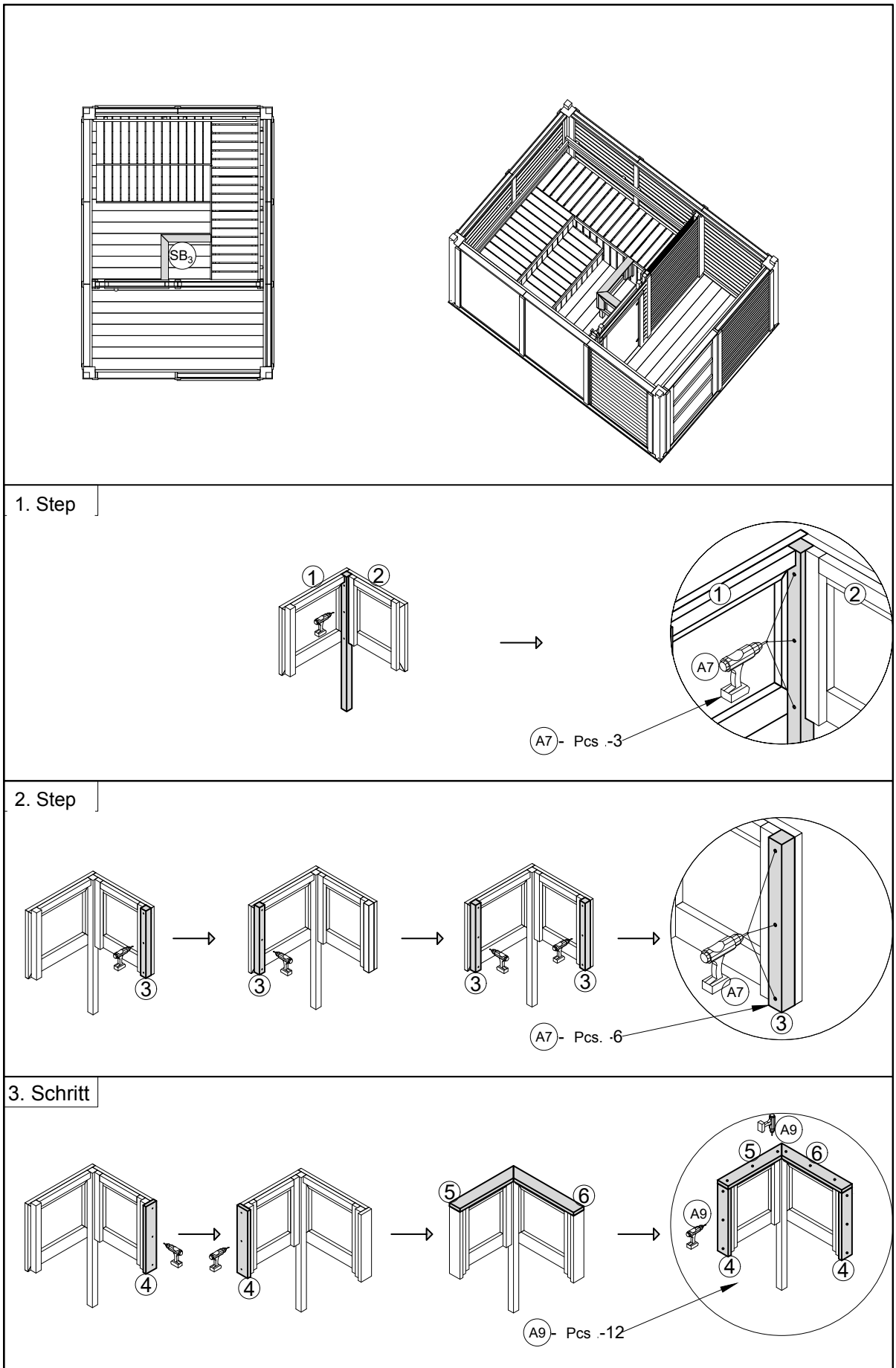

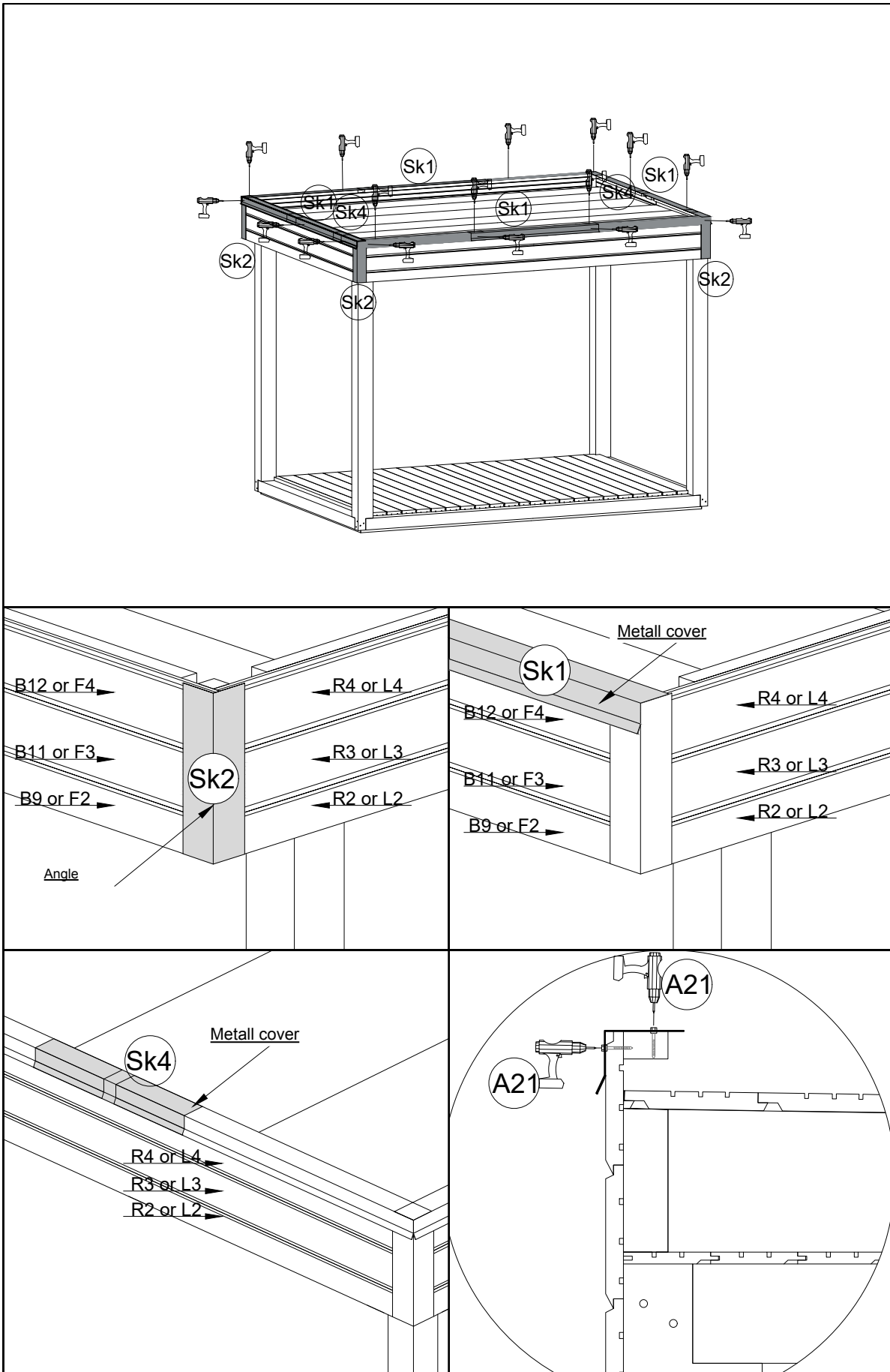

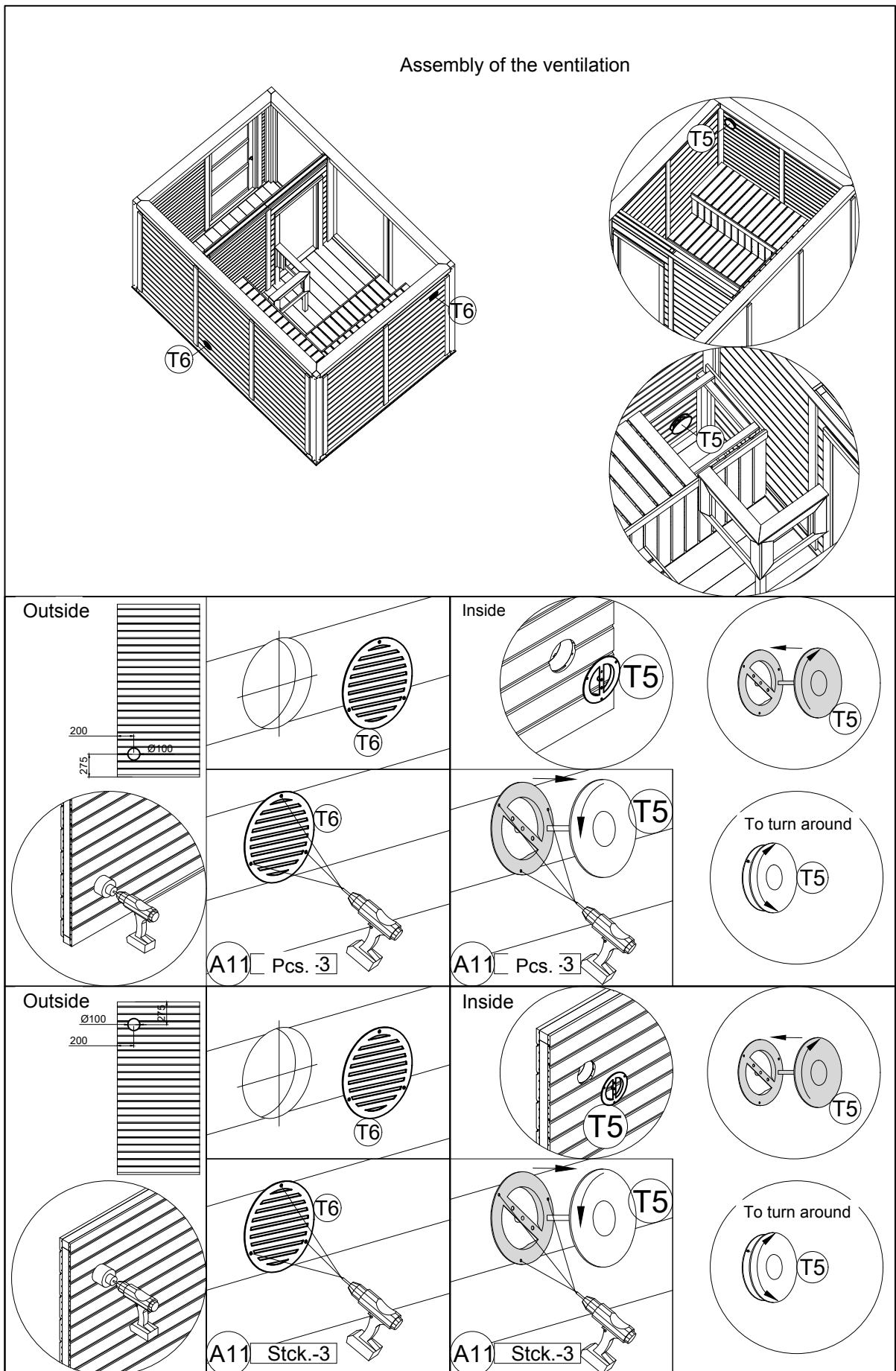



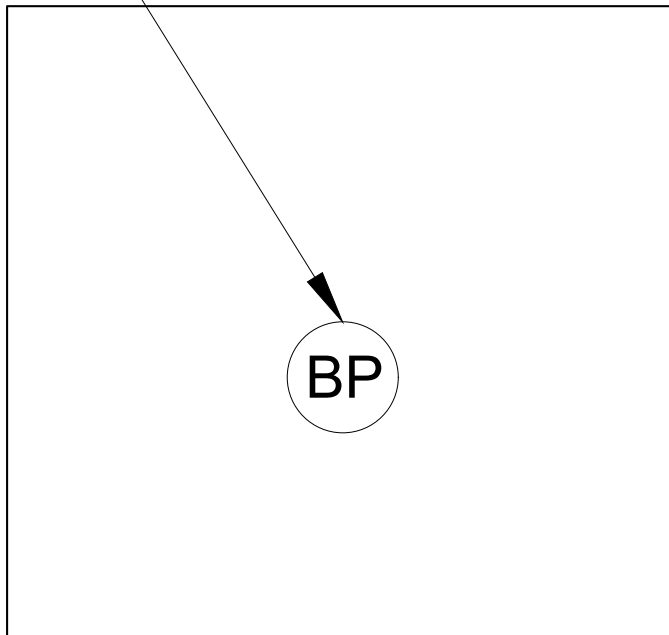
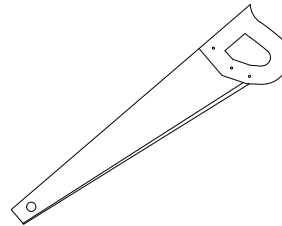
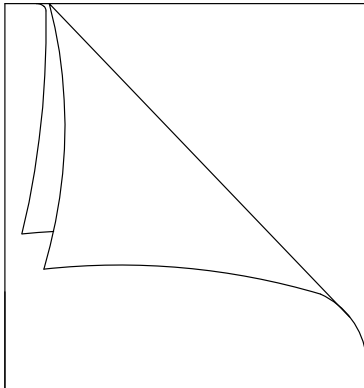

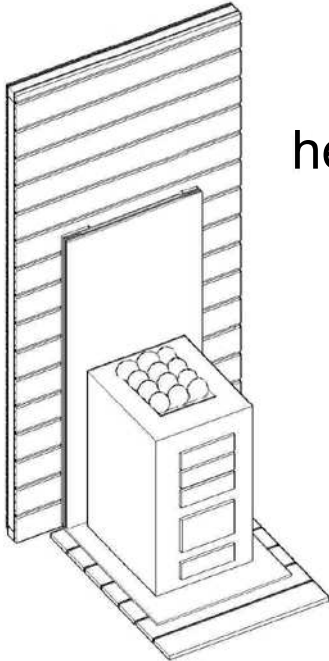
Please pay attention to the  
assembly instructions of the  
sauna heater!





## Assembly of the heat protection panel

1		700hx600x10
2		700hx70x10
3		800hx600x10
4		900hx600x10

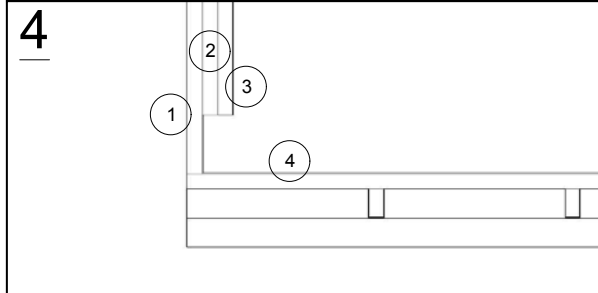
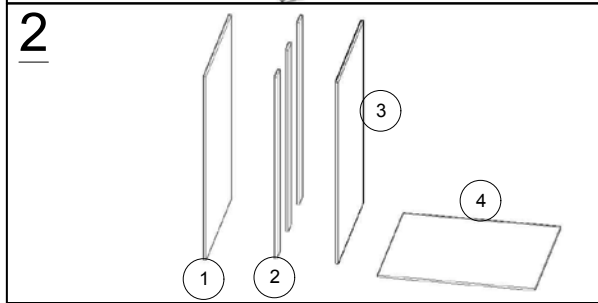
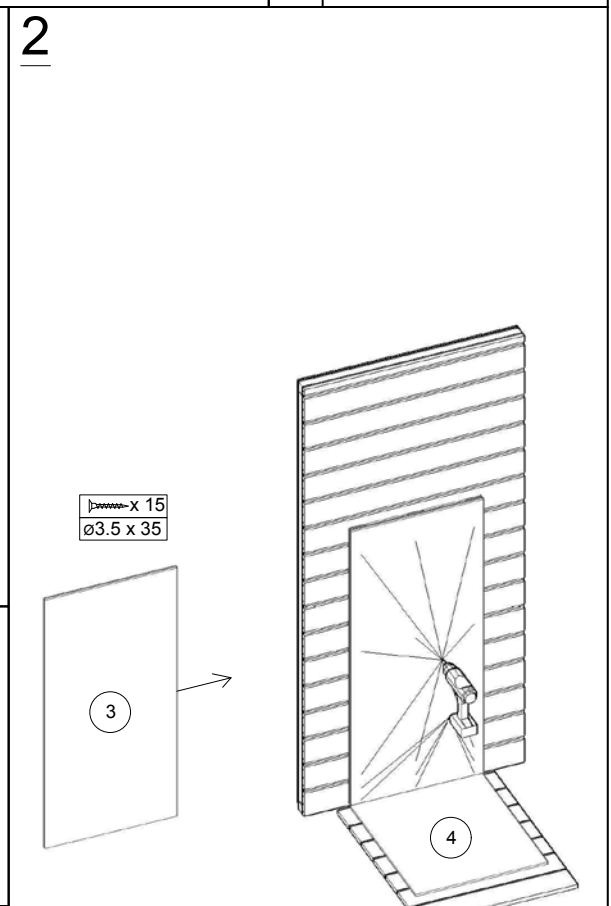
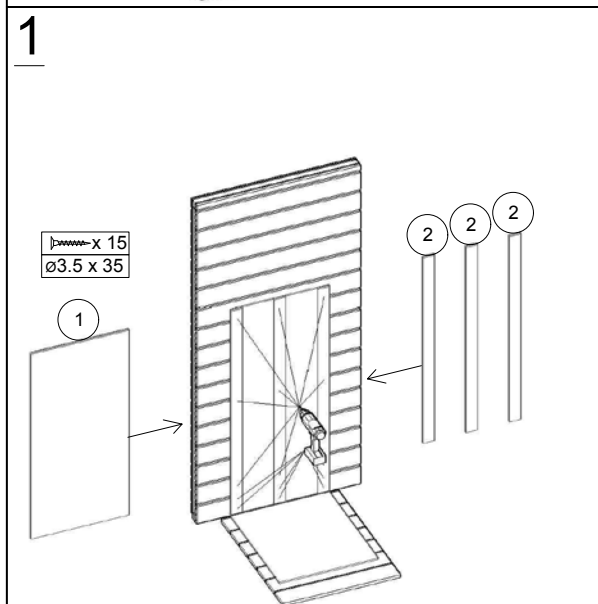



# Service Guide

## The quality of our products is very important for us.

**Should a complaint nevertheless arise, please note the following information:**

### Delivery

If you notice any visible damage upon delivery, please record this with photo evidence and the delivery driver needs to write it down on the consignment note/delivery note. If the damage becomes apparent when you open the package, please also take a photo proof. Please include the photo evidence when reporting your complaint.

### Report your complaint

Please submit your complaint using our digital complaint form. You will find this in the service section on our website at <https://www.finnhaus-wolff.de/service/garantie-service>.

### The following criteria are requested there:

- Order number, delivery note number or invoice number from Finnhaus Wolff
- Home inspection number – can be found on the packaging and/or in the documents included in the package. This number enables us to make a clear assignment.
- Component list –please mark the positions that correspond to the damaged/missing part of the item. Please also indicate the number of the required parts.

Add this component list with your notes and the home inspection number to your complaint. Our service team will take care of your complaint immediately.

### Do you still have questions about submitting your complaint or a question about your Finnhaus product?

Frequently asked questions and extensive information on how to deal with a complaint can be found in the help center on our website at <https://support.finnhaus.de/hc/de>.

**Thank you for your support!**

# General information about wood

By deciding to buy wood, you should be aware of the following: Wood is a natural material. Variations in surface, grain, structure and varnish penetration depth is not a reason for complaint, but rather a characteristic of real wood. Your garden house, sauna house, pool or other products are made from the natural material wood. The used wood is a unique, living nature material, which was processed in the country of origin after a careful selection. It is unique and characteristic in every way. No two pieces of wood have the same shape, structure and color, so color shades can't be avoided. Bumps, cracks and large or small knotholes are evidence of growth for years and originality.

All of these features are evidence of natural origin and make each piece unique. However, this natural and rustic character, which makes wood so special, also need you to consider that wood has some restrictions that must be consciously accepted. Despite the most careful selection of materials and the most modern production methods you need to consider the special features described above and the inevitable properties of the material wood. These aspects cannot be claimed.

## 01

### Swelling and shrinking behavior

A typical property of wood is the shrinkage or swelling of the material. As an ongoing process, it tries to adapt to the ambient humidity. Depending on the actual humidity, the wood cells absorb or give off water. As a result, the volume of the wood changes. For example, a board can become wider or narrower. Every wood "works". This effect had been considered when calculating and designing the static.

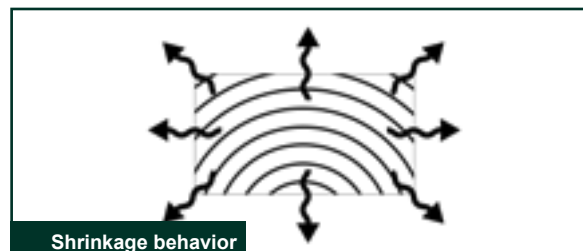
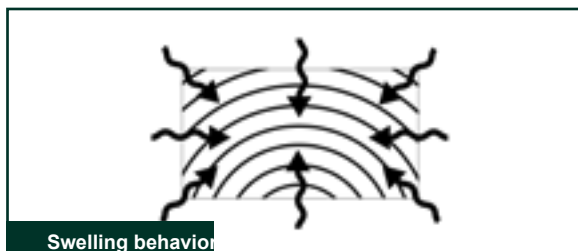

## 02

### Knots, grain, tree edges and cracking

Due to the natural, non-uniform structure, wood can crack during drying the natural material. Depending on the location and weather, this can occur and recede. According to DIN 4074 such dry hair cracks are permitted and do not negatively affect the static and durability. No tree grows knot-free and absolutely straight. In nordic wood can mainly be found firmly grown branches, but not continuous holes caused by branches falling out (on wall planks). Large amounts of branches are permitted for roof and floor coverings as well as tree edges on the back without limitations so that the visible surface can be processed. The grain always appears slightly different, it reflects the growth conditions of the tree. This special character of the wood is represented by the knots and the grain.

**We bring the holiday in your garden**

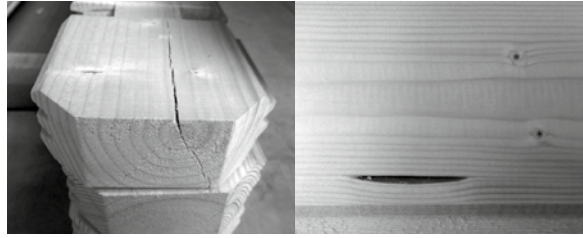

## 03

### Surface of the wood

Planing against the grain and/or in the knot area can make the wood rough. Depending on how rough it is the surface of the solid wood, you should use an abrasive (sandpaper or similar) to smooth it. Sand the wood exclusively in the direction of the grain. To get the sanding dust out of the pores as completely as possible you should use a soft brush or vacuum cleaner.

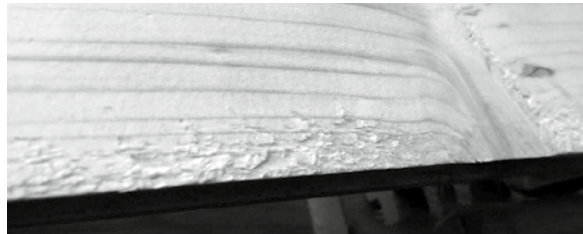
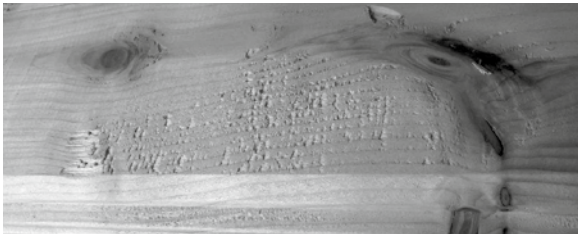

## 04

### Pitch pocket

Pitch pockets are cavities filled with resin and can be found in many needle tree species. Especially in summer the resin in fresh wood is warm and flows out from natural, resin-filled hollows. The pitch pocket can also be opened by sawing or planing and the resin comes out. Resin leakage has no influence on the stability of the wood. Dry rests of resin can be removed with a knife.

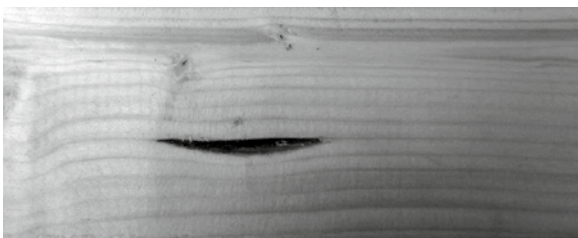

## 05

### Color shades

No two boards are the same because every tree is one unique piece. Depending on the type of wood, including heartwood and sapwood differ in color. The ones for garden houses typical wood type spruce shows in its natural state minor color differences.

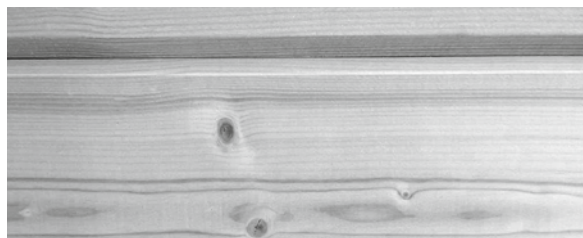

**We bring the holiday in your garden**

# 06

## Deformations

Deformations that can be fixed with screw clamps are to be tolerated.

# 07

## Attaching external materials

Planks, window or door frames, which are screwed or nailed together and consequential damage due to improper installations and modifications (Shelves/Brackets) aren't reasons for a complaint.

# 08

## Condition of the foundation

Warping of doors and windows due to incorrectly constructed and faulty foundations that are not even and consequently the doors and windows are not closing correctly, is not a reason for complaint.

# 09

## Warping of windows and doors

A slight warping of the windows and doors (ca. 1 – 1,5 cm) should be accepted, as long as the functionality is guaranteed.

# 10

## Gable construction

Due to their design, during transport or installation, the corners of the gable can break off. That is no reason for a complaint as these gables has no static functions. Just attach the corners with wire pins, wood glue or similar during the assembly of your garden house.



Gable construction Detail



Gable construction

## General information sheet

01

### Control of the component list

Please check using the attached list the individual parts of the house for completeness and possible damage within 8 days of receipt.

02

### Storage

If you don't want or can't begin right after checking the component list with the assembling the material should be stored flat and protected against weather influences such as moisture and direct sunlight (preferably in a closed and unheated room).

03

### Preparation of the underground

The foundation beams should be lying on solid ground e.g. concrete slabs, strip or point foundations made of pavement or grass grid tiles. The surface must be even and flat, so that your house later stands safe, straight and level.

04

### CARE

You should paint your garden house as quickly as possible after construction inside and outside (at the latest after 1-2 weeks). We recommend to use for the outside walls first a primer with impregnation primer/Blue protection and then a coat of paint with a wood protection, and for the indoor walls you should use a transparent moisture regulating glaze.

**IMPORTANT:** Also doors and windows need to be painted inside and outside! Through the individual properties of the wood the color shades can vary after painting. The durability of the wood will not be influenced. Repeat the painting regularly. Check regularly whether the roof is tight, so you can avoid consequential damage.

04

### CARE

For roofing is usually used Roofing felt used as initial covering puts. This should counteract after a short time Durable roof covering replaced become. Alternatively, you have the option of your to cover the garden house with roof shingles, these last up to 10 years and more. For monopitch and flat roofs, the roof is ideally with self-adhesive ones Sealing membranes/welding membranes to cover, this will last 30 years and more\*.

05

### Surrounding of the house

A slight warping of the windows and doors (ca. 1 – 1,5 cm) should be accepted, as long as the functionality is guaranteed.

The roofing felt is excluded from the warranty.



\* Please check windows and doors annually and adjust the fittings (hinges) if necessary. This ensures correct function.



## **DGfH-Information**

### **Sheet to avoid mold infestation on exterior painted surfaces**

#### **Content:**

- 1. Introduction**
- 2. Causes of mold infestation**
- 3. Preventive measures**
- 4. Remedial action**

#### **1. Introduction**

Molds are a large group of fungi that mainly belong to the Ascomycetes and the collective group Fungi imperfecti. The mold spores can be found everywhere in the air in different concentrations depending on the season. If the spores fall on a substrate that offers them sufficient moisture and nutritional conditions, they germinate. A single cell thread (the hyphae) initially grows out of a spore, which branches out, possibly growing together with cell threads from other spores and thus forming a so-called fungal lawn (the mycelium), which can be colored very differently depending on the type of fungus. Above all the color of the new spores that are forming the fungal lawn gives it a characteristic, often species-specific coloring. Green and grey-blue to blackish tones are most common, but many different colors are possible. The color shades on the materials do not always come from the hyphae or spores of the mold. They can also be a result of the metabolic process between the fungi and the components of the materials.

All organic and almost all biochemical substances can be used as a food source for mold, e.g. wood, paper, glues, varnishes, binder paints, plastics. It is not always the material itself where the spores have fallen on, that forms the nutritional basis for the fungi. The slightest dirt deposits with organic components (dust, fats, oils, etc.) that enable the fungus to grow. Mold is always an indicator of increased moisture on the surfaces or within the components. Molds that appear directly on (untreated) wood only use the wood ingredients such as sugar, fats and waxes to subsist, but not the wood substance itself. In the case of wood-based materials, binders and fillers can also serve as a food source for the fungi. The molds themselves do not cause any loss of strength in the wood. So mold is not a wood-destroying fungus. Therefore, numerous paint systems and impregnation solutions classified as wood preservatives are not

effective against mold and consequently mold-resistant paints cannot be used as wood preservatives within the meaning of DIN 68800 (means as a preventive measure against wood-destroying fungi). On the untreated wooden surface, the wood ingredients in the cut cells are freely accessible to mold. Since different tree species produce different amounts and types of ingredients, the different types of wood can be colonized by mold to a varying extent. Molds, which also include blue mold, can damage paints applied to the wood and in consequence neutralise their effect, means the mold makes their barrier effect against dripping water ineffective. Blue mold colonizes over uncoated areas of the wood and breaks down layers of paint from below. Mold can break down the coating film itself, creating entry points for moisture.

## **2. Causes of mold infestation**

An essential condition for the germination of the spores and the further development of all fungi, including molds, is a moisture level on the component surfaces and/or inside the components. This moisture must be maintained over a sufficiently long period of time or at short, more or less regularly recurring intervals (e.g. by spraying with water).

This leaflet does not talk about the causes of indoor mold infestation, e.g. on wallpapered or cleaned surfaces. This kind of mold is usually caused by the physical properties of the building, i.e. local moisture accumulation, the causes and prevention of which have already been published in numerous publications.

The following causes can be considered for the increasing mold infestation on external wooden surfaces in recent years:

- Increased exposure to moisture

Due to unfavorable geometric conditions (which, for example, can cause external corners which are much colder due to an unfavorable heat flow), insufficient ventilation or shading of the components.

A separate problem is the occasional mold growth on external roof overhangs. Actually there is some research to develop targeted preventative and remedial measures.

However, some of the problems certainly result from locally increased air humidity and even dripping water due to falling below the dew point, due to a lack of isolation on the external underside of the roof. The choice of type of wood or the origin of the wood can also make a difference.

- Extensive reduction of mold-resistant components in paints and coatings

Following the increasing desire of consumers, a large number of paint products have had their compositions changed to products with the "Blue Angel", which by definition necessarily also leads to a reduction in the concentrations or the complete elimination of mold-resistant components.

- Different suitable wood materials

With wood materials made from peeled veneers, the barely visible peeling cracks that are always created during the peeling process often increase moisture accumulation on the surface. Glues with a high alkali salt content also lead to higher moisture levels of the wood materials glued in this way. In addition, some types of wood (e.g. maritime pine, birch) due to their higher natural strength or sugar content offers a better supply of nutrients for mold than other types of wood.

Therefore, a weather-resistant gluing does not mean that such wood materials can be used unhesitatingly in outdoor areas. This explains why some manufacturers do not approve their plywoods for use in outdoor areas.

Fibre boards that have not been coated by the manufacturer and recommended for their intended purpose, shouldn't be used in outdoor areas due to the type of glueing. This restriction expressly does not apply to fibre boards which are used for thermal insulation in rear-ventilated constructions where they are not directly exposed to the weather!

- Unsuitable surface coating

Suitable paints for weathered components made of wood or wood-based materials must, in addition to other requirements, e.g. aging resistance and adhesion, also have sufficient moisture protection for the underground. Usually, products should therefore be used whose moisture protection is classified as suitable for dimensionally stable components (stable) or conditionally dimensionally stable components (semi-stable) according to EN 927. The layer thicknesses specified by the manufacturer must also be considered, in particular edges, chamfers and corners must be rounded.

### **3. Vorbeugende Maßnahmen**

If you need protection against mold infestation, you should use paint products and systems for which the manufacturer guarantees mold-resistant properties on the container or in the technical data sheet. When such products are used properly, no complaints have occurred so far. The anti-mold effectiveness of a product (paint, etc.) depends on the active ingredients used, their concentration as well as on the entire composition of the product. Therefore, no individual active ingredients or product groups can currently be named here.

### **4. Remedies**

If you discover a mold infestation, simply cleaning the area with a damp cloth is sometimes sufficient in the initial stages of the growth. ·

- Water and denatured alcohol in a ratio of 90:10.
- 5% soda solution (pharmacy)
- Vinegar is often mentioned, but it serves as a nutrient for some kind of fungi!

Small amounts of surfactant can also be added to these substances to reduce surface tension. But they have no preventive effect. The fungi can colonize again after treatment.

It is usually necessary to combat the mold lawn with products:

- High-percentage alcohol (e.g. 70% denatured alcohol) and 2% salicylic acid.

Attention: Not to be used on large areas in rooms, as explosive air-alcohol mixtures can occur!

- 5% or 10% hydrogen peroxide solution (pharmacy)

The use of hydrogen peroxide can be helpful as it kills mold and has a bleaching effect at the same time. Because of its bleaching effect, it is used especially in cases of blue stain fungus. Hydrogen peroxide has no preventive effect against new infestations either.

- 5% ammonia solution

Although often mentioned, 5% ammonia solution should not be used because ammonia has a strong irritant effect on the respiratory organs. ·

- Household cleaners with "active chlorine", the so-called chlorine bleach.



If you inhale the spray mist of such products, harmful organochlorine compounds are formed in the body. Therefore, make sure to follow the safety instructions! It kills mold and has a bleaching effect at the same time, which is an advantage for colored mold lawns. Be careful with metal surfaces: corrosion effect!

- Agents that contain quaternary ammonium compounds (quats) usually have a selective effect. They will not combat some kind of fungi, but they lose their food competitors and can develop even better.

It is important to ensure that after such treatment of the surfaces, the compatibility of the agent used and the existing paint system and the subsequent paint system must be checked.

For a permanently mold-free surface, either the moisture must be reduced through structural interventions, or the application of a new paint system, in this case mold-resistant, is necessary.

It should be noted that the active ingredients against mold in the coating products only have a limited duration of effectiveness and therefore a frequent care is required. The care intervals depend, among other things, on the amount of moisture and the intensity of UV radiation on the painted surfaces.