

DANCOVER[®]

.com

Manual
for
Gazebo
4,36x2,95x2,7m

Assembly Instructions

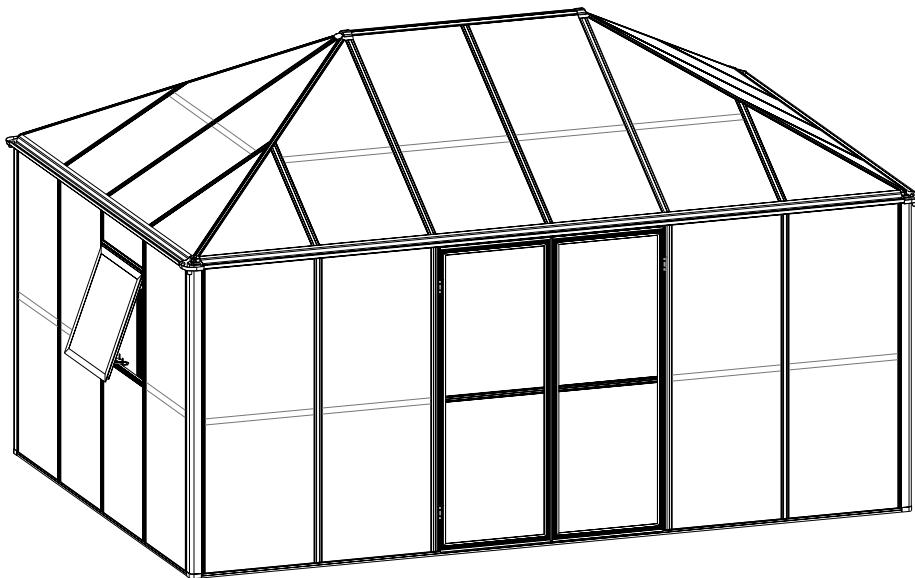

PRODUCT SIZE(LxWxH):436x295x270cm
PLEASE READ CAREFULLY BEFORE ASSEMBLY

CONTENTS

1. Assembly Advice	Page 1
2. Product Features	Page 2 - 3
3. Parts List	Page 4 - 6
4. Roof Vent Assembly	Page 7 - 8
5. Door Assembly	Page 9 - 11
6. Base Assembly	Page 12 - 13
7. Framework & Glazing Assembly	Page 14 - 31

Assembly and Maintenance Advice

1. For safety purposes, we strongly recommend that this product is assembled by at least two people.
2. Some components have sharp metal edges. Please be careful when handling metal components. Please wear gloves, shoes and safety goggles during assembly.
3. Lay all of the components on a soft carpet or blanket to avoid any scratches or damages.
4. DO NOT climb or stand on the roof. Heavy articles should not be leaned against the greenhouse.
5. Keep the roof and gutter clear of snow, dirt & leaves. Allowing snow to build up on the roof may damage the product.
6. Unlike steel, if the paint finish is scratched this will not harm the aluminium underneath.
7. When your product needs cleaning, use a mild detergent solution and rinse with cold clean water. Do not use acetone, abrasive cleaners or strong detergents to clean the panels.

Tools Provided:

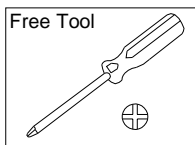

Tools Required when Assembly (Not Provided)

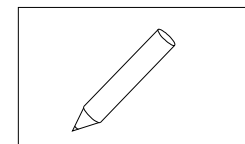
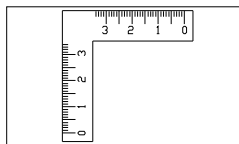
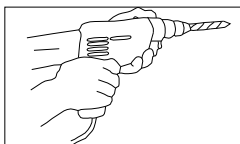
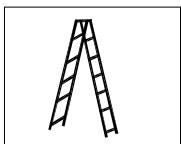
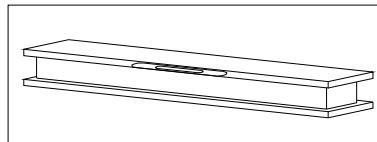
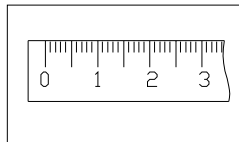
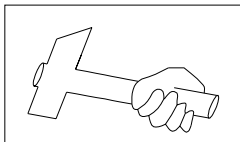
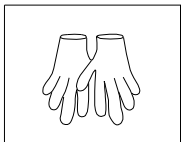

Assembly at least by two Persons



Important:

Rubber is not provided if you choose polycarbonate sheet as glazing panel.

Functions and Features:

1. Compared with traditional greenhouses this new product features many significant improvements. The hollow box profile aluminium framing is much stronger than other greenhouses and it can withstand much greater pressure.

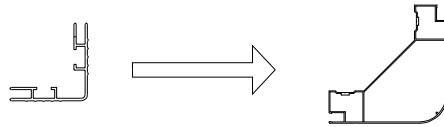

2. Base anchor brackets are included as standard with expanding bolts to ensure a secure fixing into concrete or paving. Alternatively, you can use the brackets to fix into a timber base with wood screws (not provided).

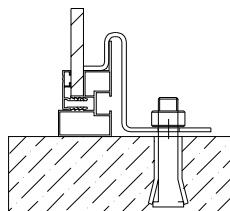

Expansion bolt
in concrete

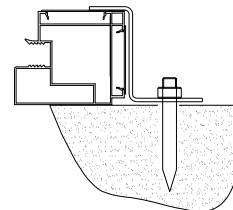

Steel bar/Lawn land

3. Our unique frame connectors make much stronger joints than conventional greenhouses.

4. The strong two part eaves beam includes an integral gutter. Downpipes are also included as standard so you can collect rainwater.

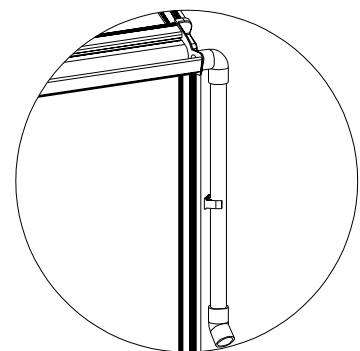

5. Manual window handles are included as standard with the roof vents. If required, automatic roof vent openers are available as an inexpensive optional extra.

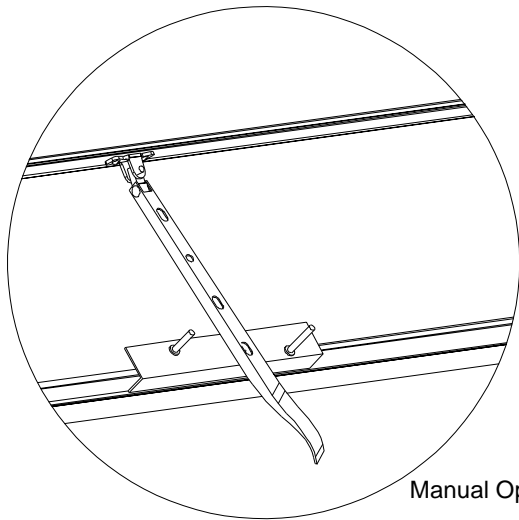

Manual Opener

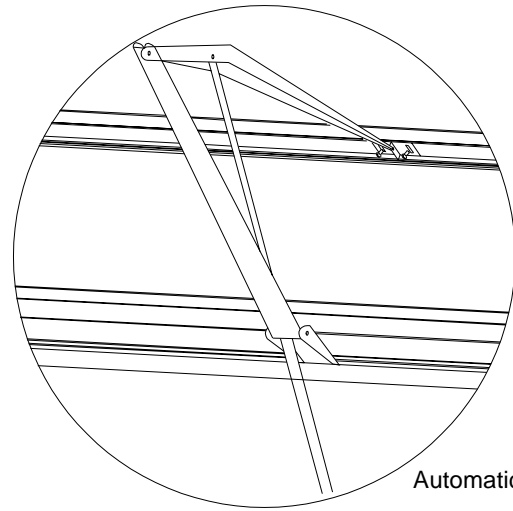

Automatic Opener



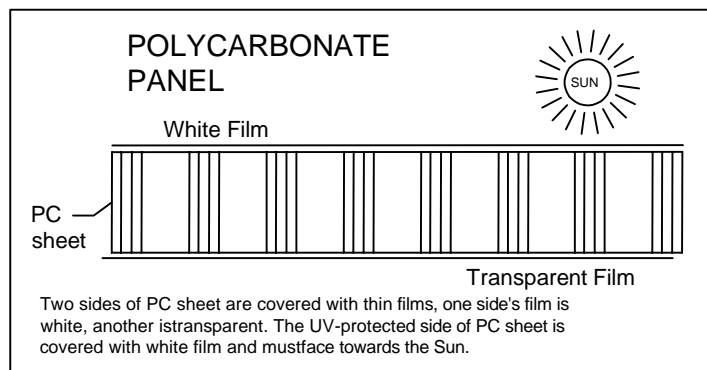





6. Remove approximately 2 inches of film from all sheet edges before installing and remove all film immediately after the construction is completed. Please ensure that the side with the white film faces outwards.

























7. POWERED SCREWDRIVER RECOMMENDED

This quality greenhouse features self-tapping screws to provide strong joints. As the name suggests, the screws tap their own thread. Driving in self-tapping screws requires more force than conventional screws. A powered screwdriver is therefore recommended.

PA152010









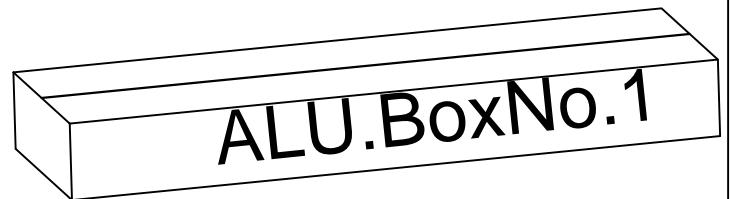
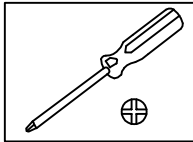

	PART	NO	QTY
1		L01A	4
2		L03C	4
3		L04A	1
		L04B	1
4		L18B	2
5		L19A	4
6		L23A	4
7		L24	1
8		L25	4

	PART	NO	QTY
		L25	4
		J39	4
		J41	4
		J40	2
		J93	4
		J92	4
		D49	8
		A01	2
		D22	18
		H43	8
		A03	2
		D52	4
		D53	4
		D56	2
		D45	8
		D46	8
		D115	2

	PART	NO	QTY
		H10	2
		S26 M5X12	246
		S27 M5X12	26
		Z08 M4.2X16	267
		Z02 Ø4X16D	5
		Z17 M4.8X16	9
		S08 M8X60	18
		M05 M5	8
		S05 M6X12	6
		M03 M6	6
		Z06 Ø3.2X10	4







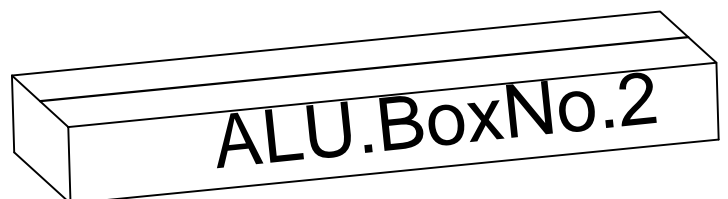

Tools Provided:







	PART	NO	QTY
1		L02E	2
2		L05A	4
3		L07A	2
4		L08A	2
5		L09A	2
6		L05C	4
7		L03A	4
8		L17	2
9		L18A	2
10		L19B	2



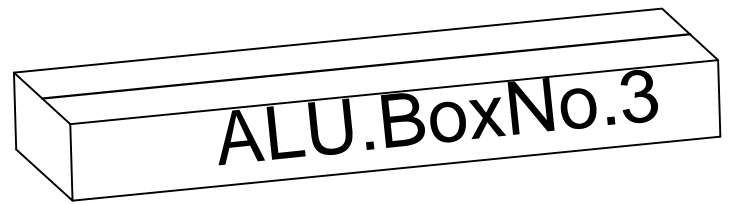



PA152010

	PART	NO	QTY
1		L03D	6
2		L03E	2
3		L05B	1
4		L07B	2
5		L08B	2
6		L09B	2
7		L05G	4
8		L11	2
		L15A	2







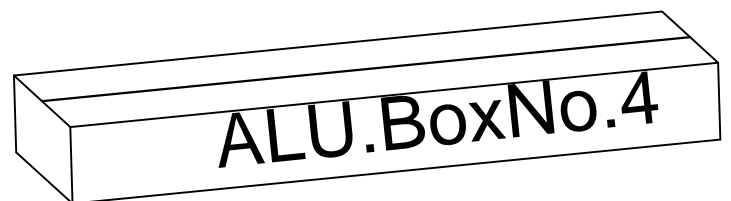





	PART	NO	QTY
1		L03B	4
2		L06A	1
3		L05E	10
4		L03A	9

	PART	NO	QTY
5		L16A	1
		L16B	1
6		L18C	1
		L18D	1
7		L20	2



PA152010

PART	NO	QTY
	Y1	4
	Y2	4
	Y3	4
	Y4	4
	Y5	16
	Y6	2
	Y7	2
	Y8	4
	Y10	2
	Y11	4

PART	NO	QTY
	J107	160M







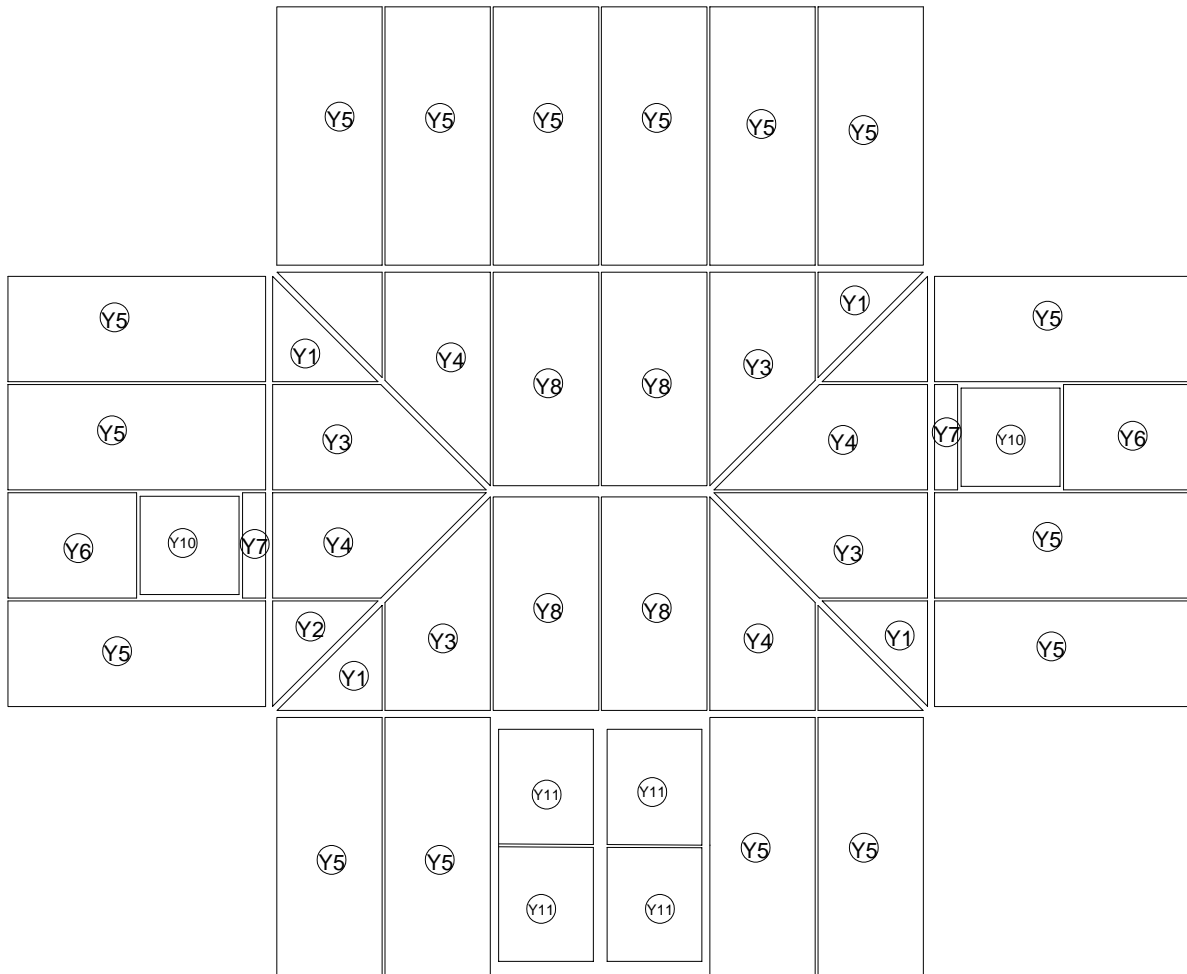
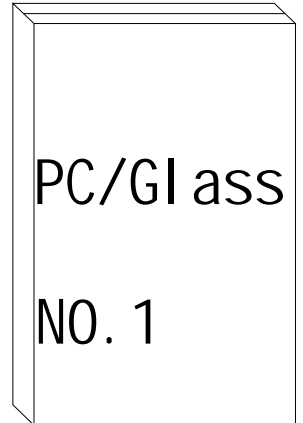

Rubber for walls & roof
(Provided for glass only)

PART	NO	QTY
	J107	98M

Rubber for walls only
(Provided for glass only)



Window

PART	NO	QTY
	L19A	2
	L19B	1
	L20	1
	D46	4
	H43	4
	Z08 M4.2X16	10
	Y10	1
	A01	1

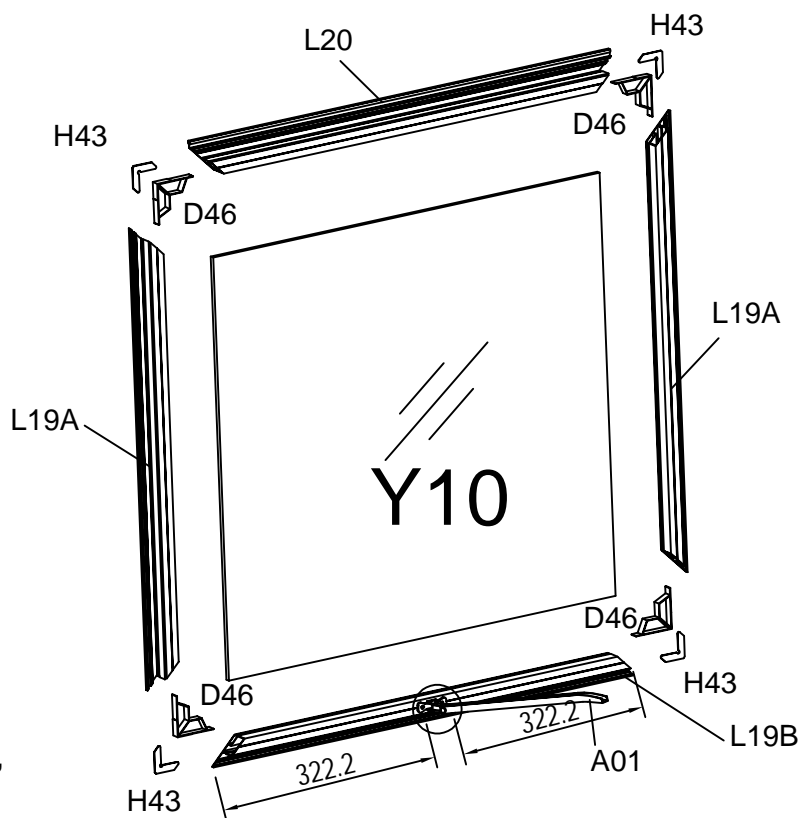

Fix A01 in the middle of L19B, 322.2mm from the ends.

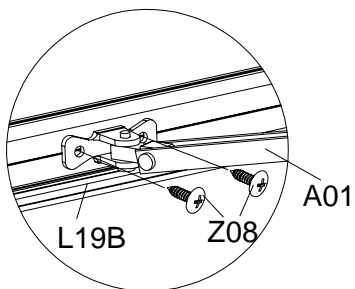

Insert H43 into the Slot of L19A, L19B & L20

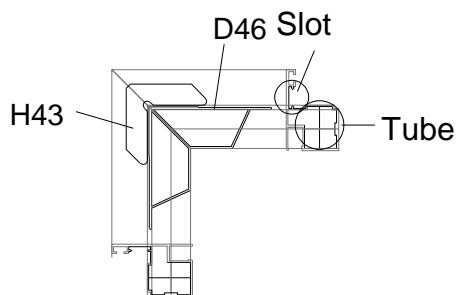



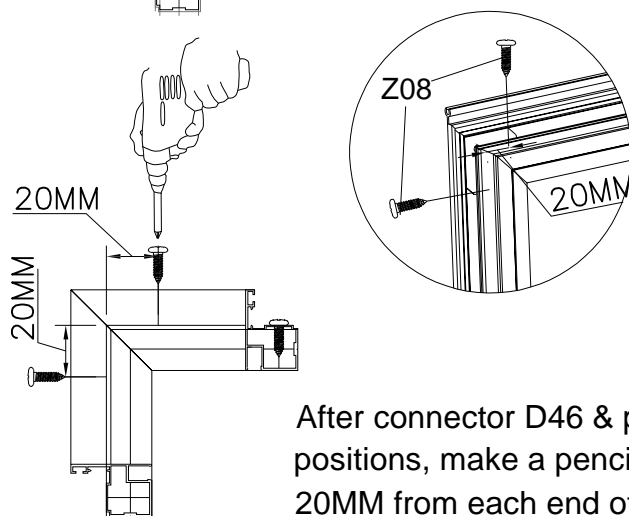

Insert Part B into the tube of L19A, L19B & L20

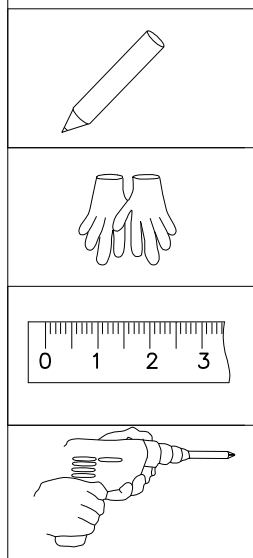

After connector D46 & part H43 are in positions, make a pencil mark at about 20MM from each end of L19A, L19B and L20. Use a powered screwdriver to fix them together with screw Z08. Make sure there is no gaps between the angle of each profile.



PART	NO	QTY
	L11	1
	L15A	1
	Z08	2
	M4.2X16	
	Z02	2
	Ø4X16D	

PART	NO	QTY
	J107	2.65M

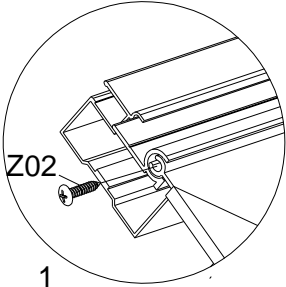
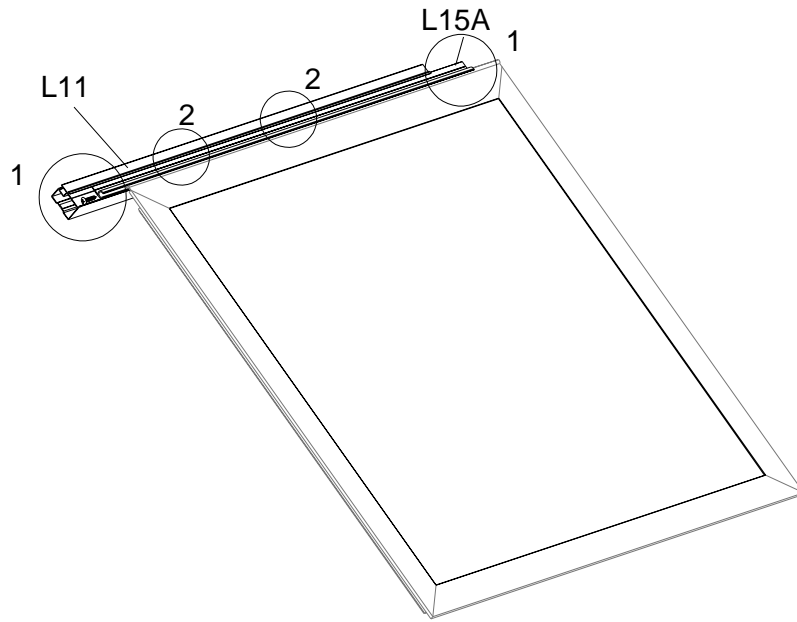

1

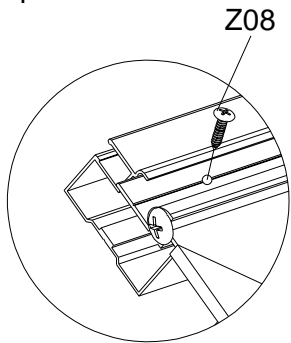

2

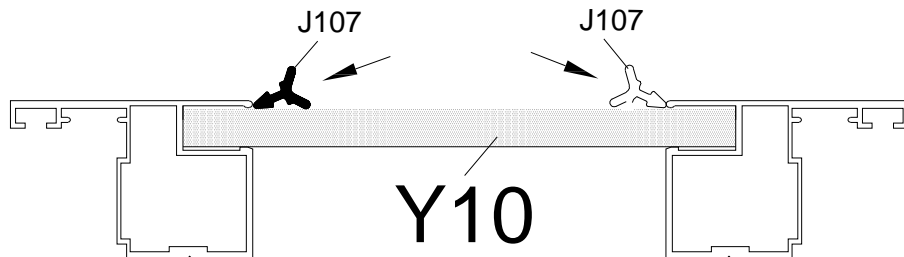

If glass is chosen, please seal it with rubber (J107) provided.
 If polycarbonate sheet is chosen, rubber is not provided.
 Please seal it with silicone sealant (not provided).

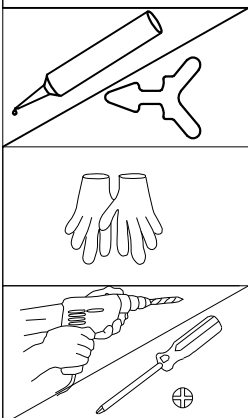

PART	NO	QTY
	L16A	1
	L16B	1
	L17	2
	L18A	2
	L18B	2
	L18C	1
	L18D	1
	L05G	4
	D45	8
	S26	10
	M5X12	
	Z08	32
	M4.2X16	
	S05	6
	M6X12	
	M03	6
	M6	
	Y11	4

Left Door

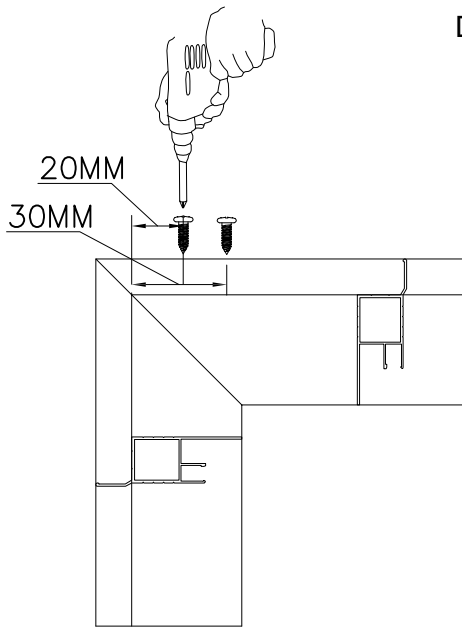
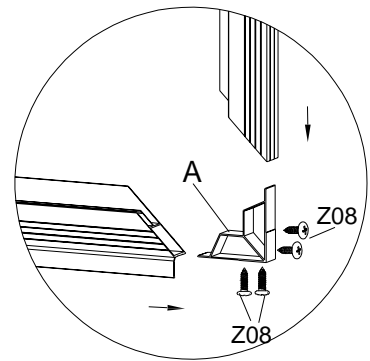
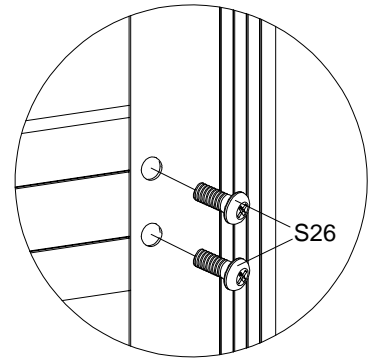
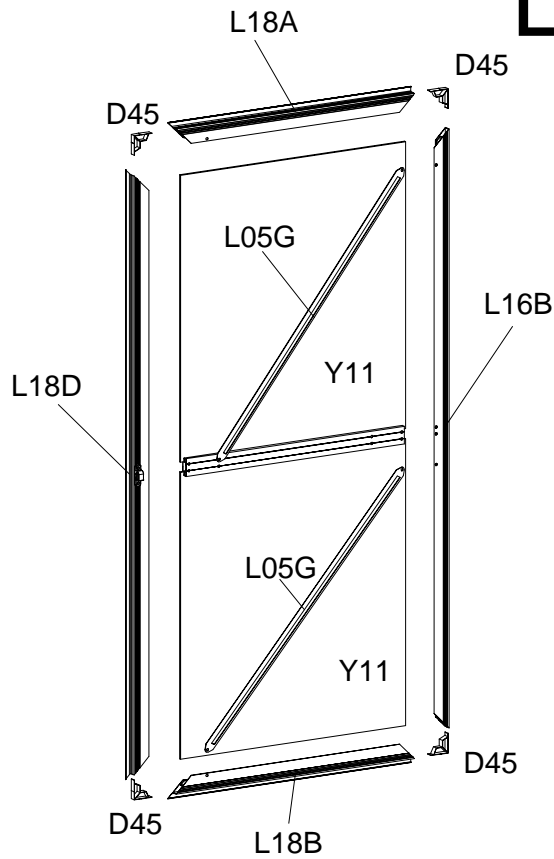

3

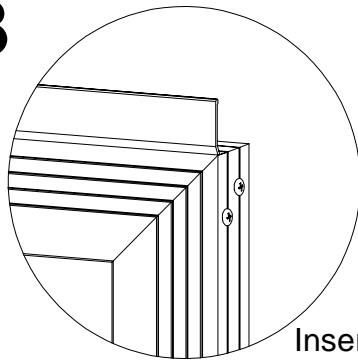

Insert Connector D45 into each end of frame profiles L16B & L18A & L18B & L18D, and then fix them with screws Z08. Before fixing with screws, please mark them with a pencil at distance about 20/30mm from each end, and make sure there is no gaps between each profile.

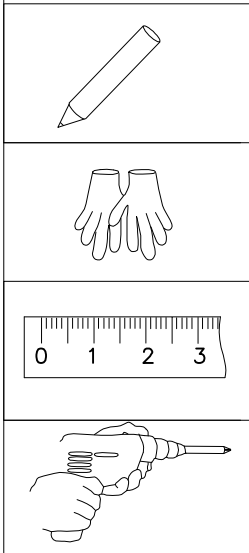
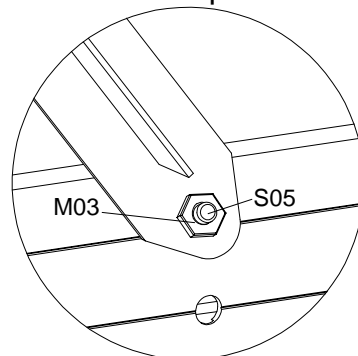
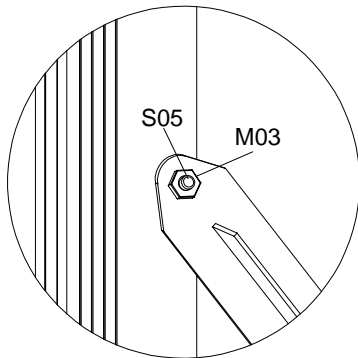

Right Door

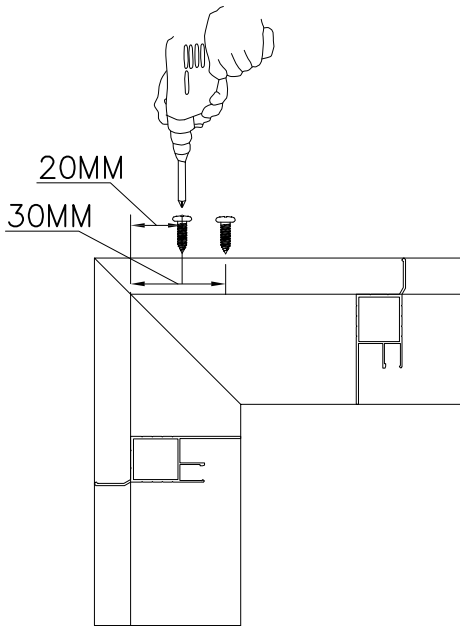
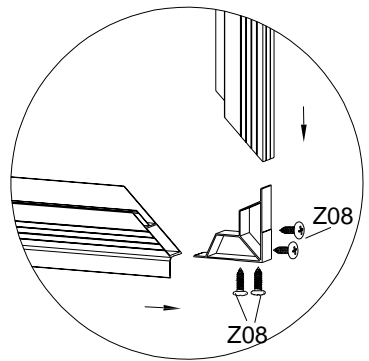
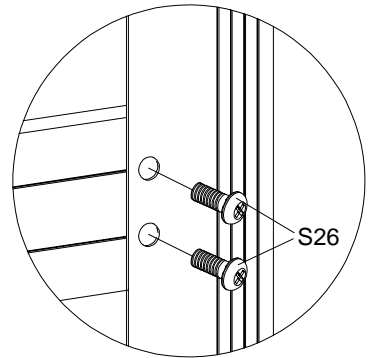
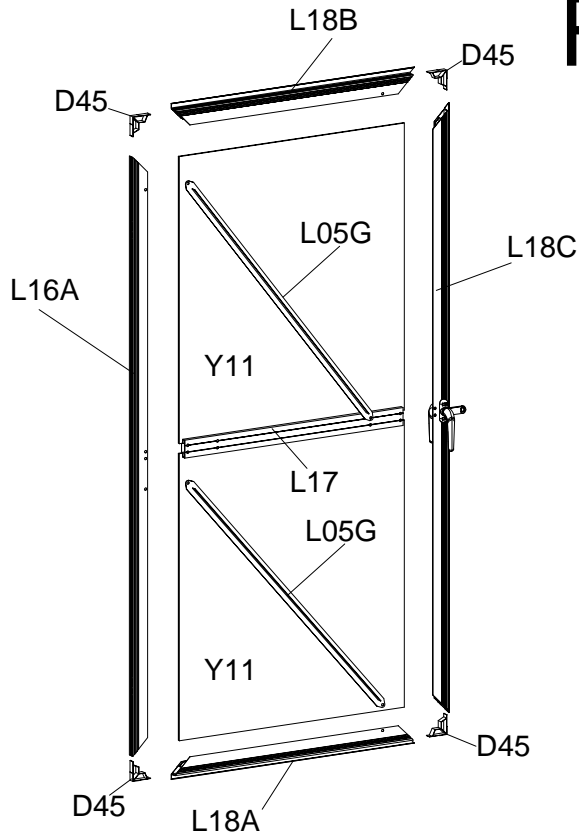

3

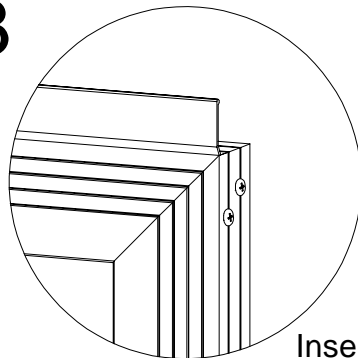

Insert Connector D45 into each end of frame profiles L16A & L18A & L18B & L18C, and then fix them with screws Z08. Before fixing with screws, please mark them with a pencil at distance about 20/30mm from each end, and make sure there is no gaps between each profile.

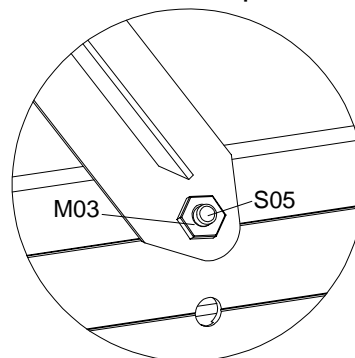
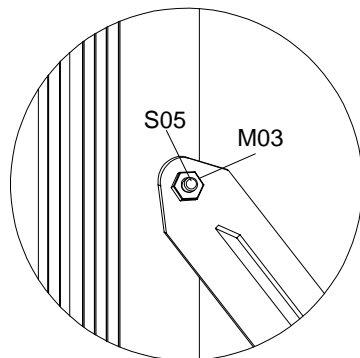
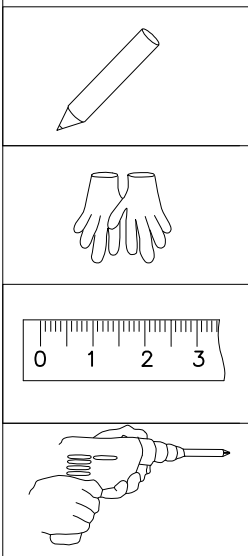

PART	NO	QTY
	J107	12.2M

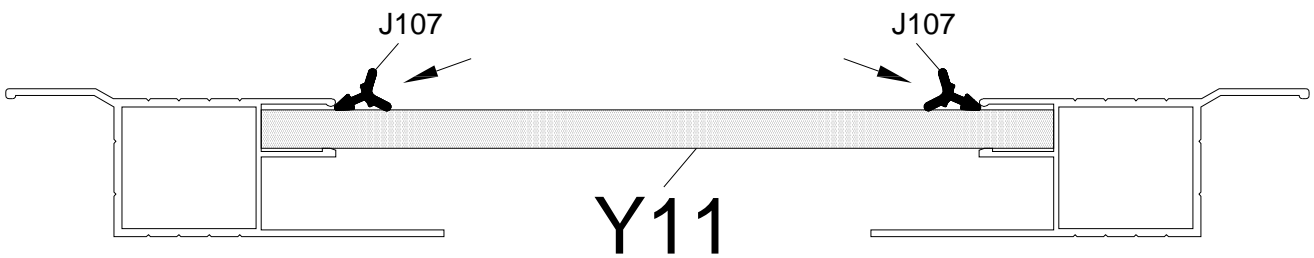
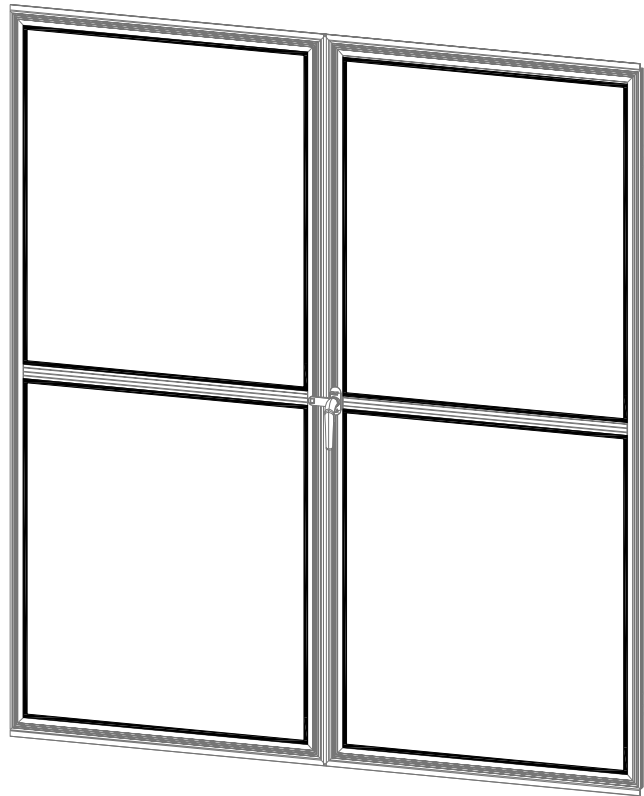

If glass is chosen, please seal it with rubber(J107) provided.

Noted:

Rubber is not provided if you choose polycarbonate sheet as glazing panel.

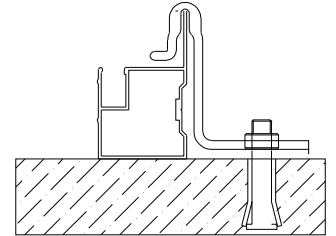
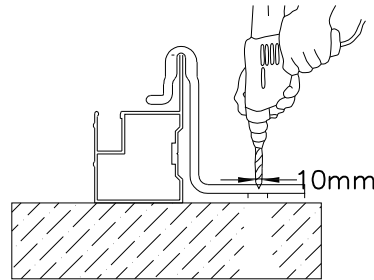
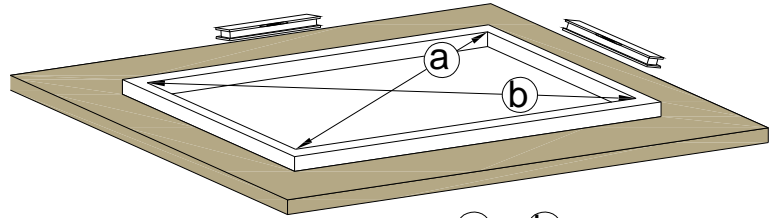
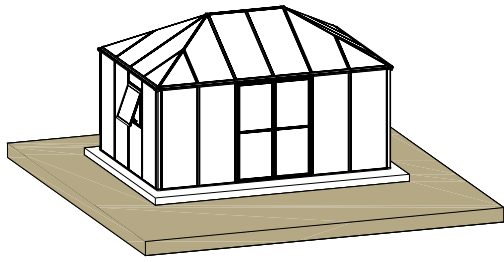

Expansion screw/Concrete ground



It is essential the dimensions a + b are the same to ensure the base is square.

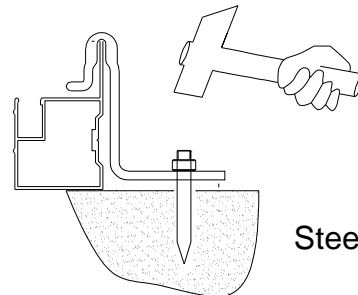
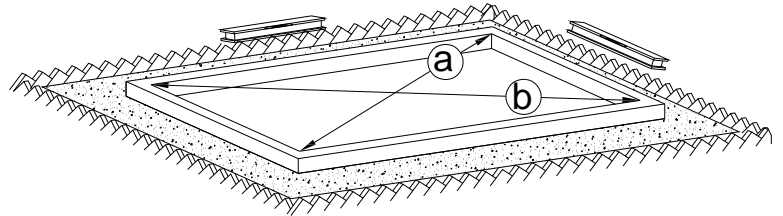
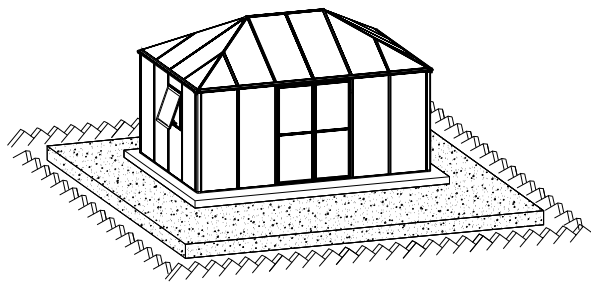

Steel pegs in soil



Support at the corners only is inadequate.

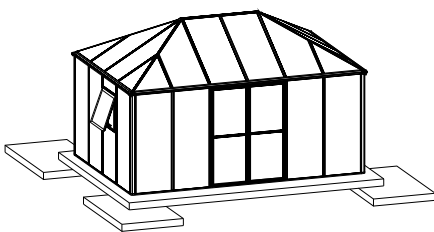

PART	NO	QTY
	D22	18
	S08 M8X60	18

Door

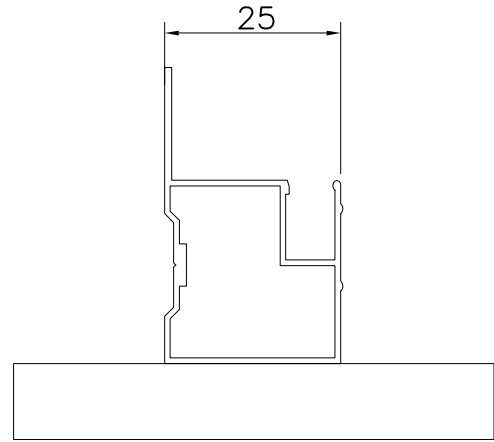
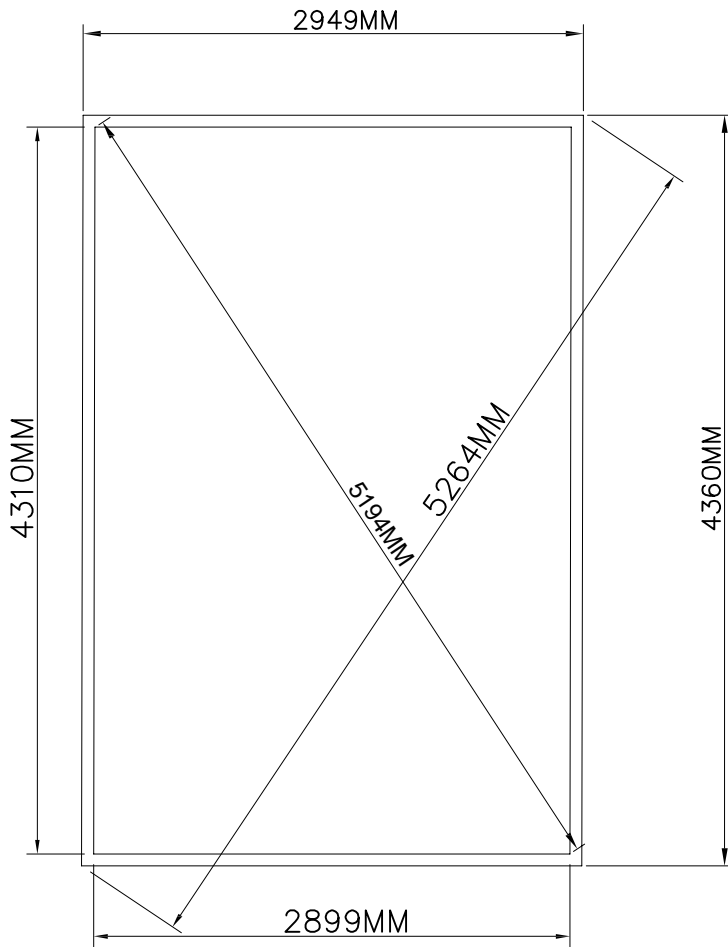



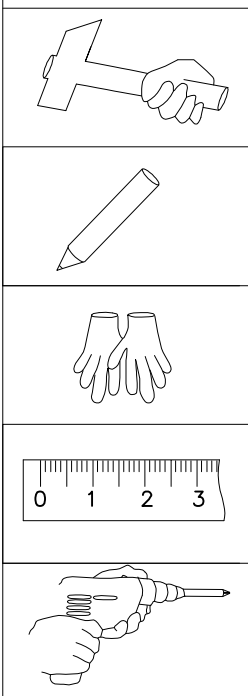
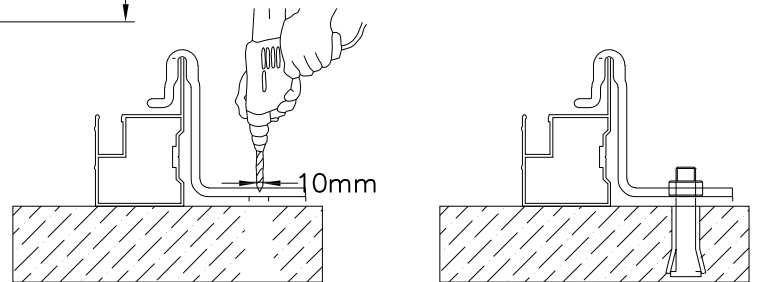



Expansion bolts assembly

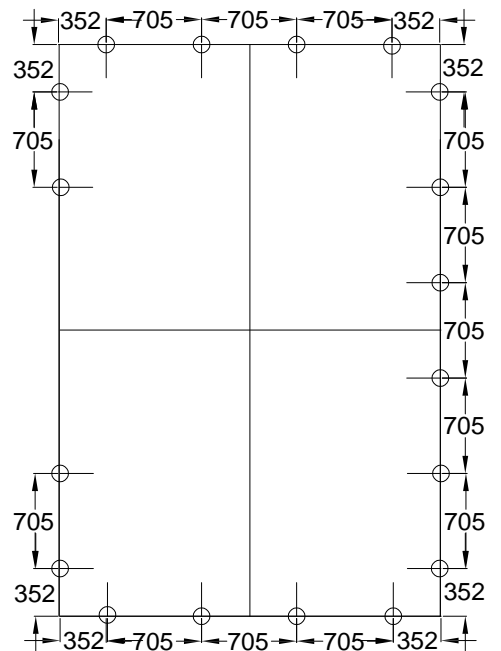

* This shows a layout for D22's positions where it is placed in the middle of the glazing panel for each section.

Door



PART	NO	QTY
	L01A	4
	L08A	2
	L08B	2
	J41	4
	S26 M5X12	8

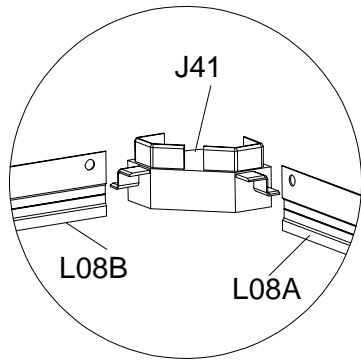
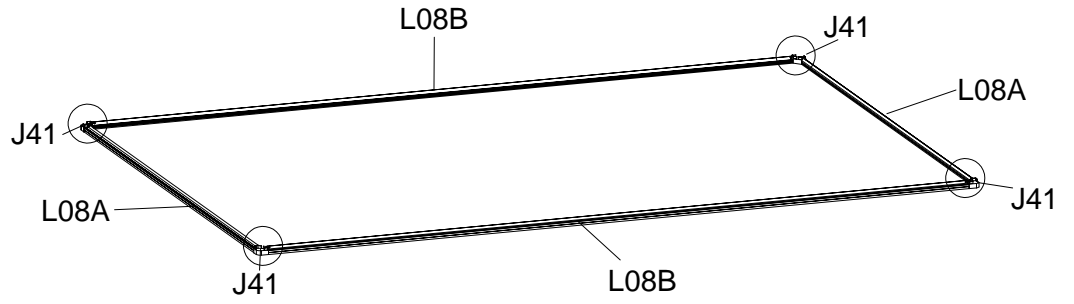



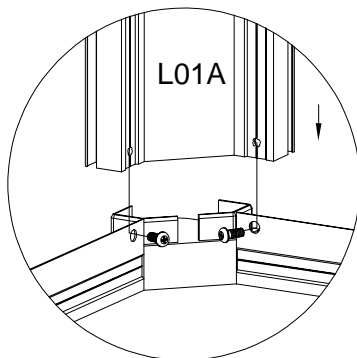
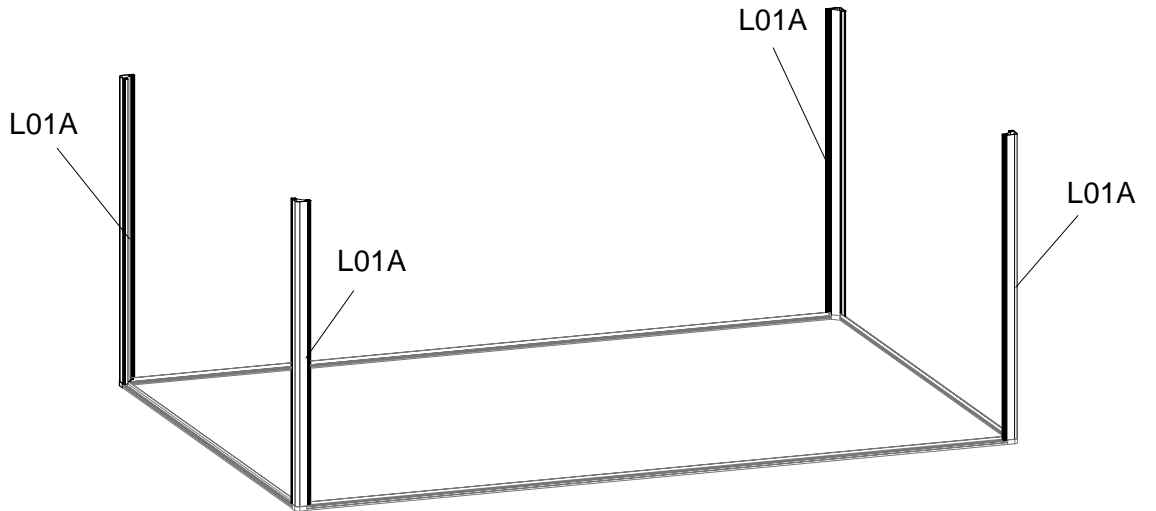

Insert J41 into the tube of L08A and L08B

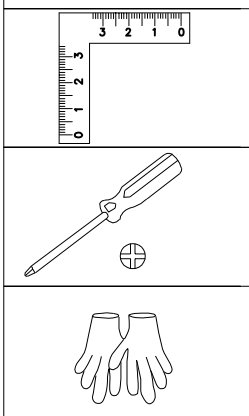

Fix L01A to L08A & L08B through J41, using S26.



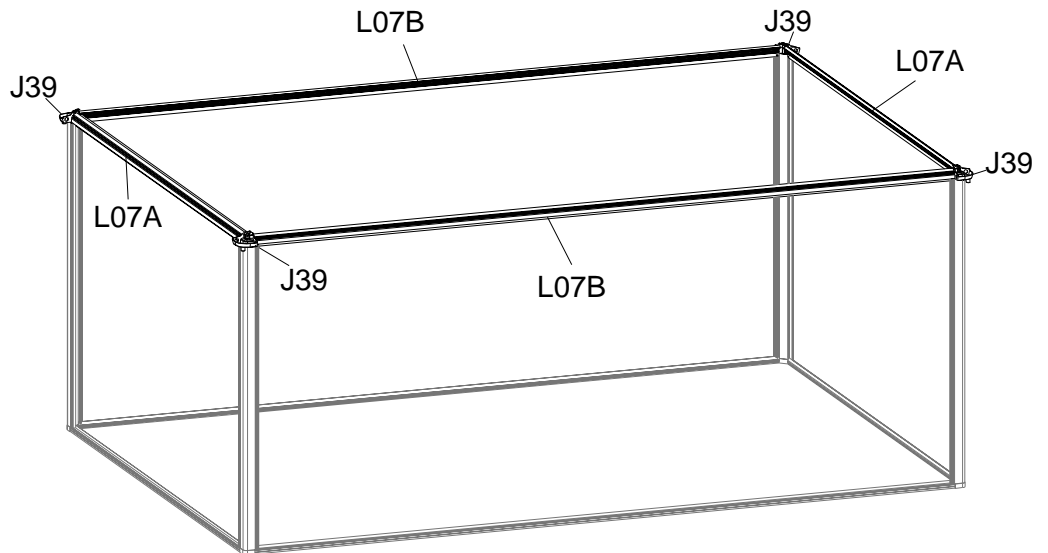

PART	NO	QTY
	L07A	2
	L07B	2
	J39	4
	S26 M5X12	8

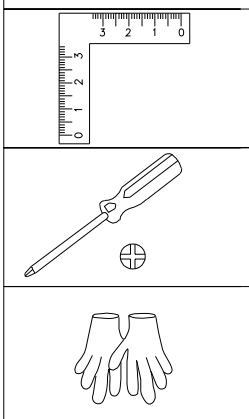
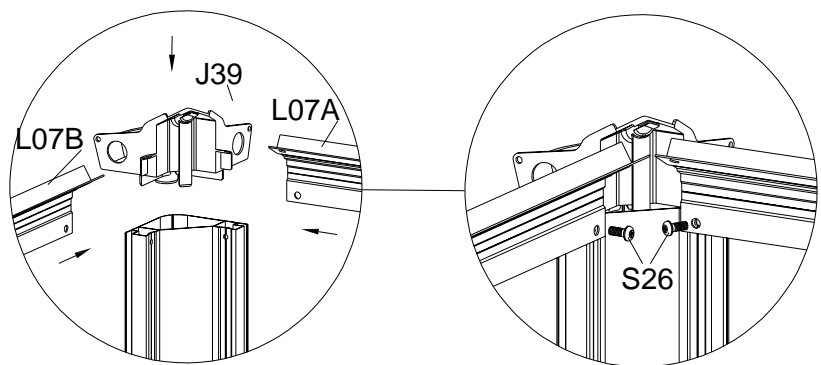

Insert J39 into L01A, and then fix L07A & L07B to L01A using S26. Make sure the angle is Right Angle before tightening them up.



PART	NO	QTY
	L03A	5
	Y5	6
	S26 M5X12	20

Back Wall Assembly

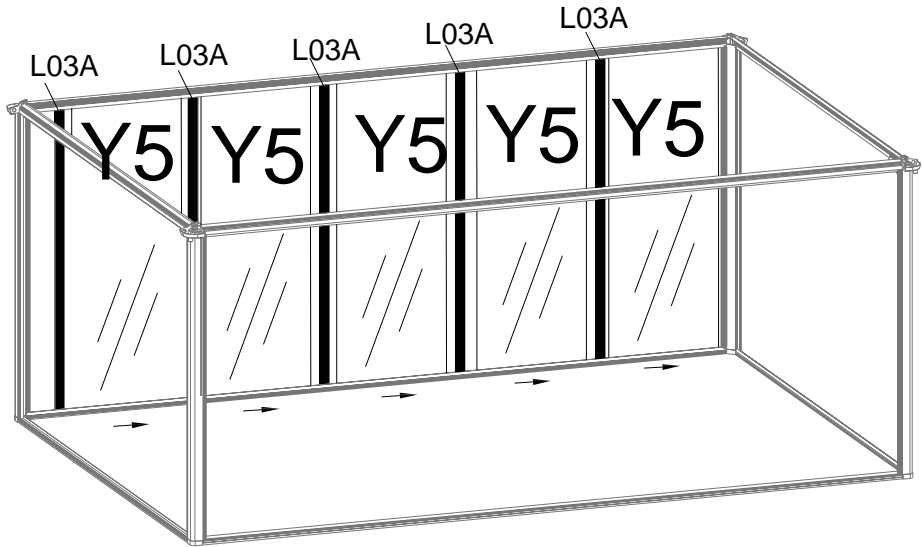

1

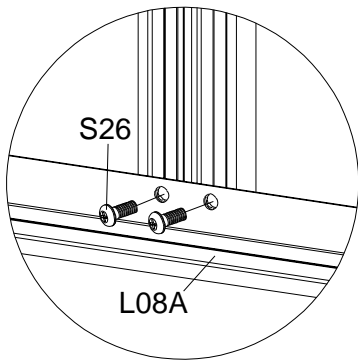





Insert Panel Y5 into the channel of L01A, and then fix a L03A to L08B & L07B using S26. Make sure the other side of Y5 is completely in the channel of L03A.

Insert another Y5 into the channel of L03A, then fix another L03A using S26. Do the same for the other 3 Y5 & L03A. Lastly, insert the last Y5 into the channel of L01A & L03A.

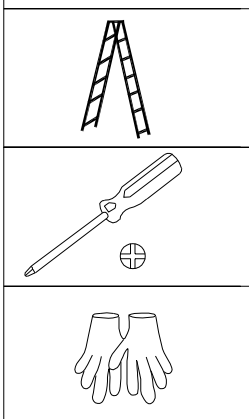
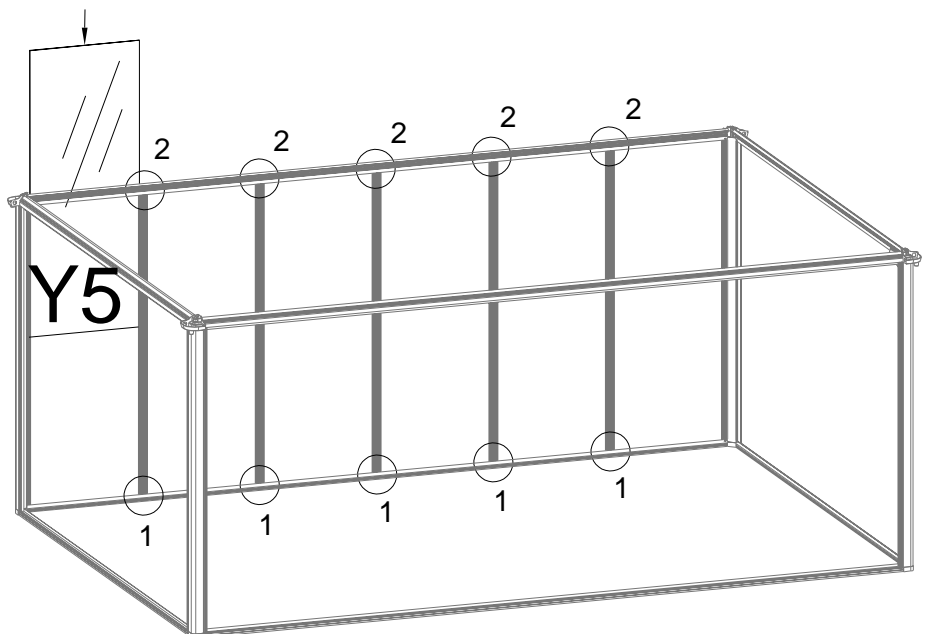
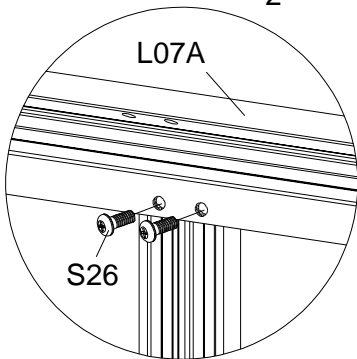
Note: If PC panel is chosen, you can fix all the L03A before inserting all the Y5.

2



PART	NO	QTY
	L03A	6
	Y5	6
	Y6	2
	S26 M5X12	24

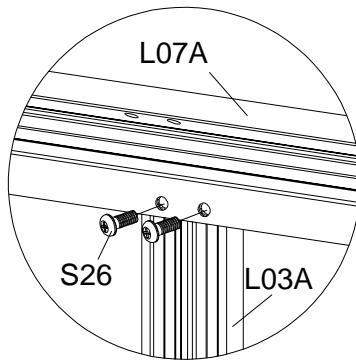
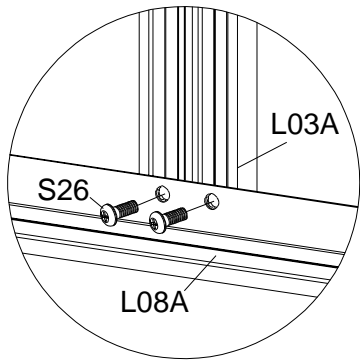
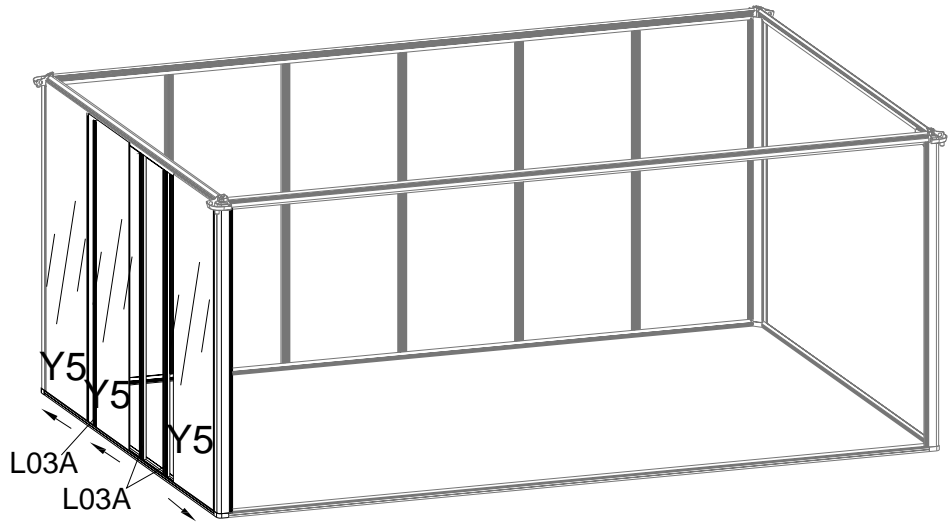







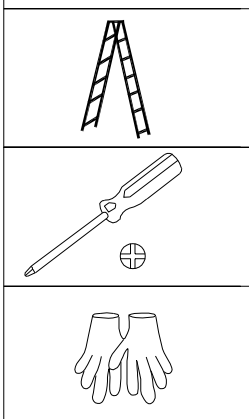
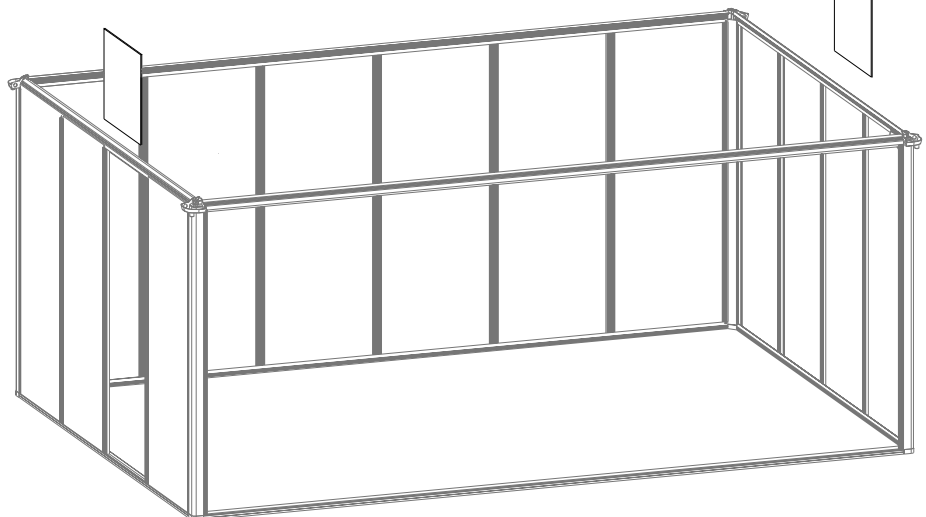

Side Walls Assembly

Do the same as the back wall assembly, Y6 is the last panel to insert in.

Y6 ↓

Y6 ↓



PART	NO	QTY
	L04A	1
	L04B	1
	L03A	2
	L05C	2
	Y5	4
	S26 M5X12	24
	Z08 M4.2X16	8

Front Wall Assembly

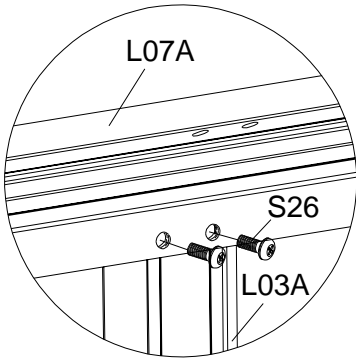
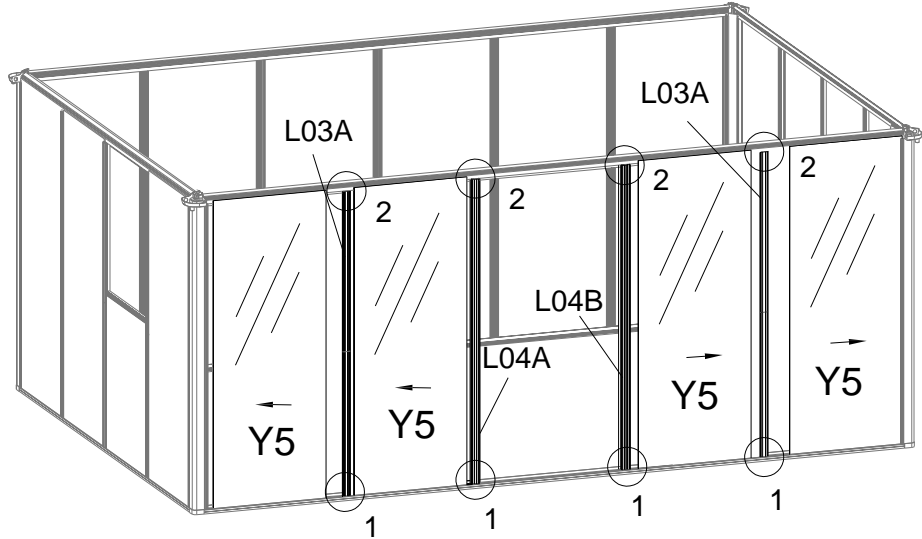



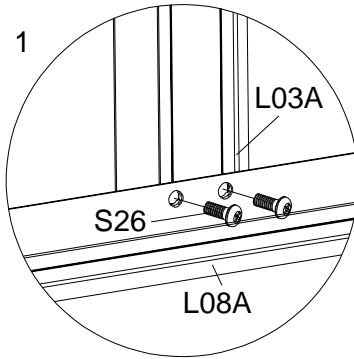

2

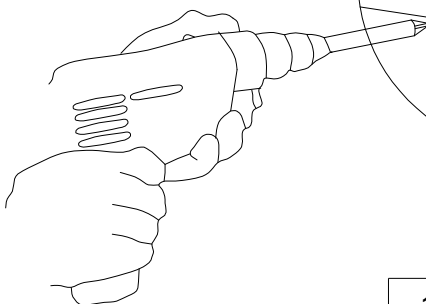
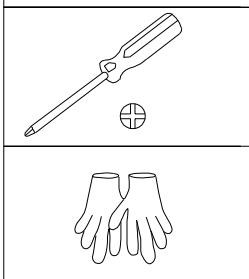
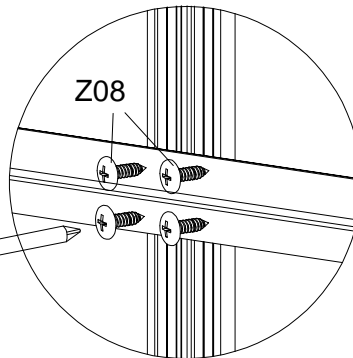
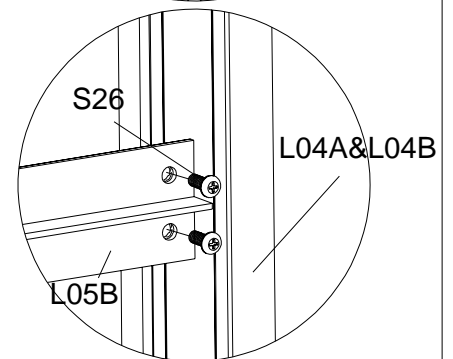
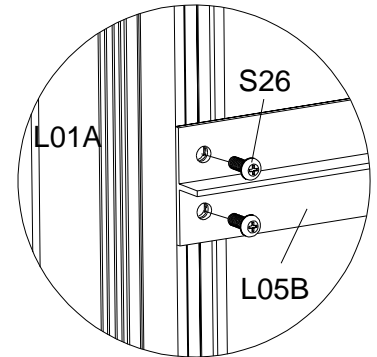
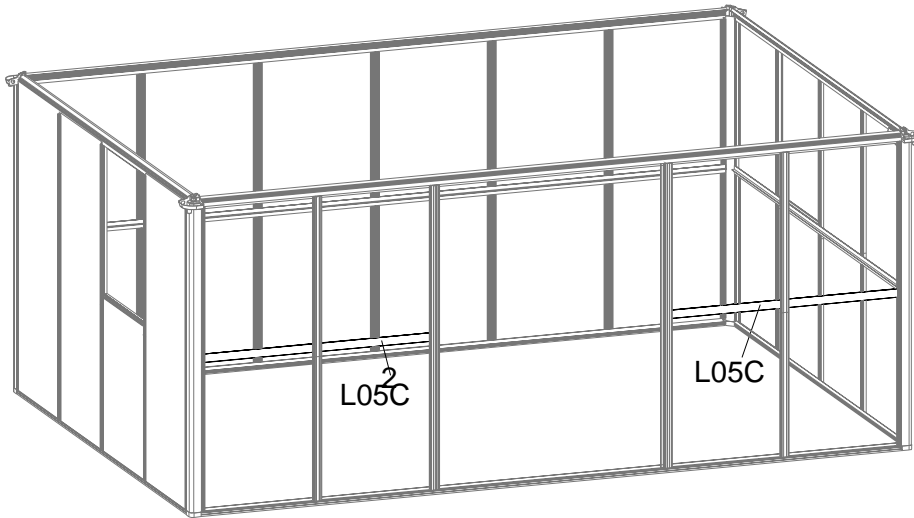

1

Fix L03A and Y5 same as the back wall assembly.
Fix L04A & L04B using S26.
And then fix L05C to glazing bars L03A & L04A/L04B using S26.



PART	NO	QTY
	L05A	2
	L05B	1
	S26 M5X12	12
	Z08 M4.2X16	44

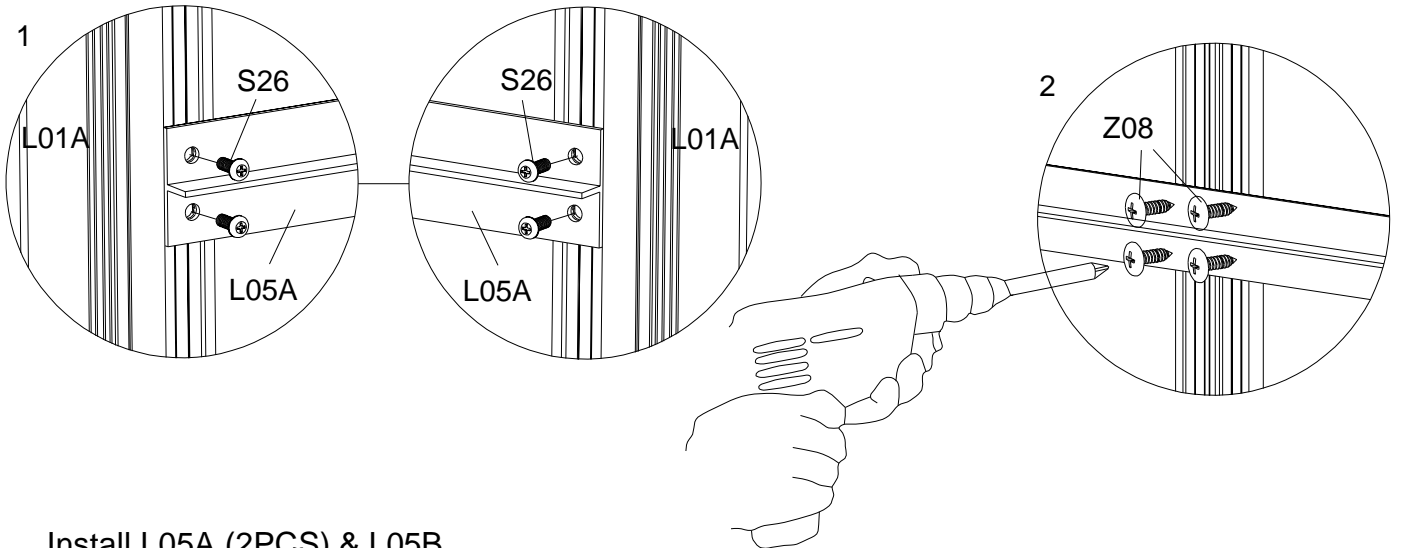
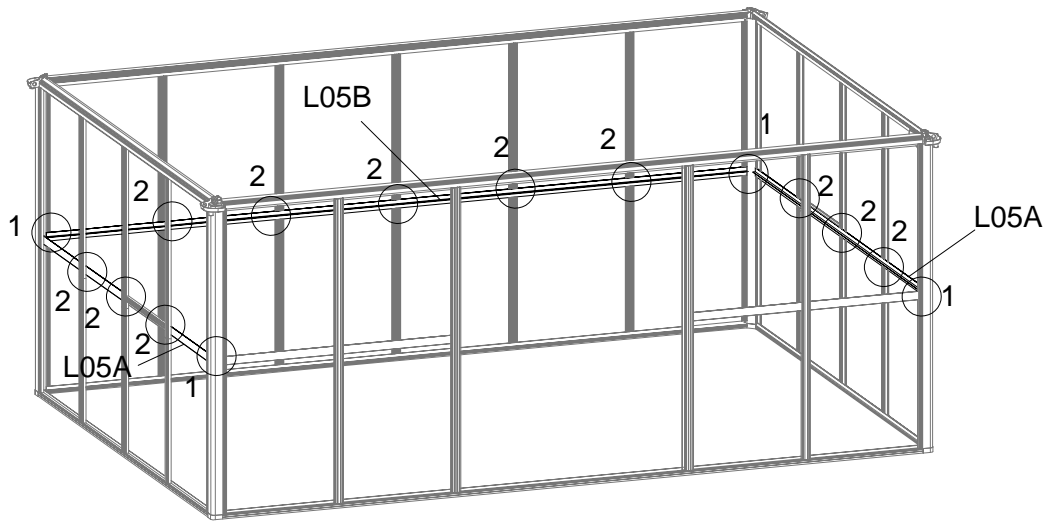





Install L05A (2PCS) & L05B

Fix two ends of L05A/L05B onto L01A using S26,

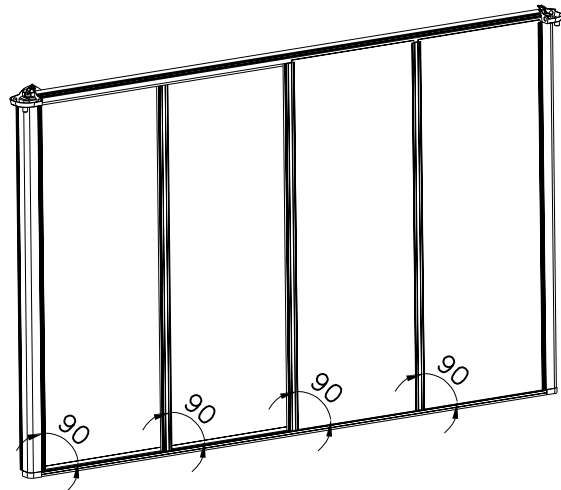
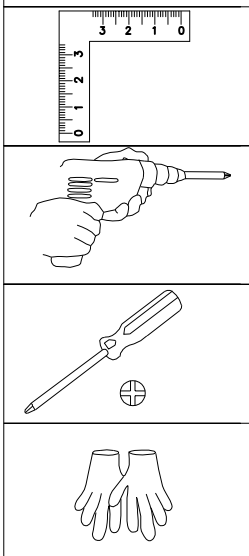
Fix L05A/L05B to L03A with the self-tapping screws (Z08) using a powered screwdriver.

Eusure that L05A/L05B is fixed at a right angle (90 degrees) to the glazing bars.





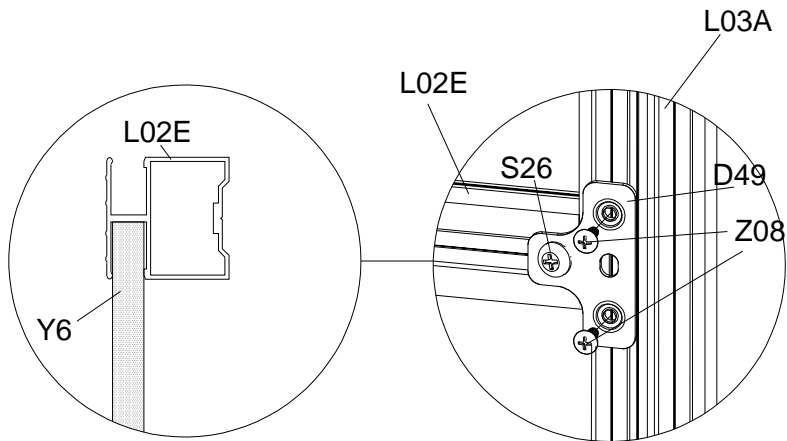
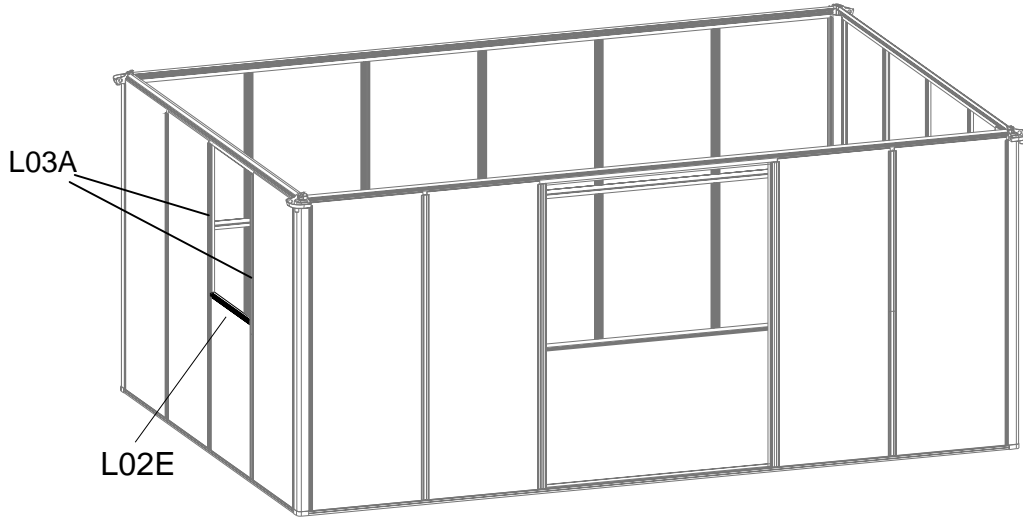

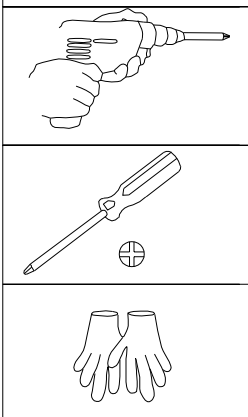

PART	NO	QTY
	L02E	2
	D49	4
	S26	4
	M5X12	
	Z08	8
	M4.2X16	



Insert the other end of Y6 into the channel of L02E.
 Fix plate D49 onto L02E and L03A, using S26 and Z08
 as shown above.



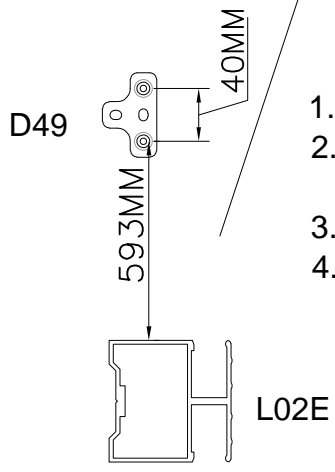
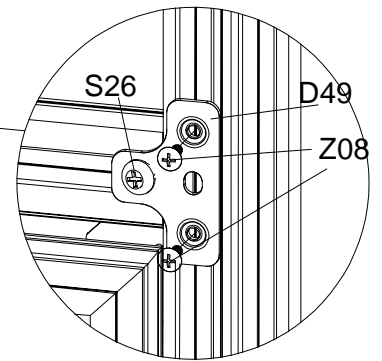
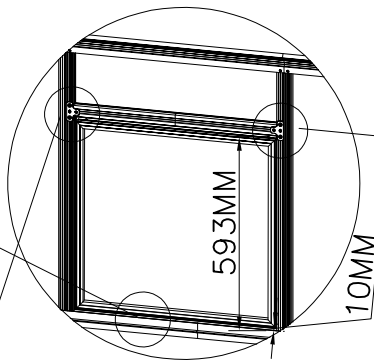
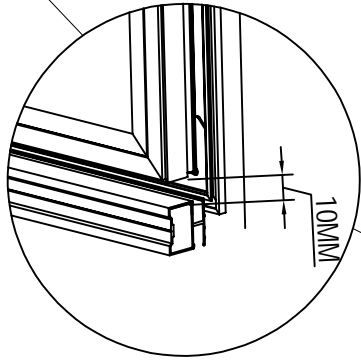
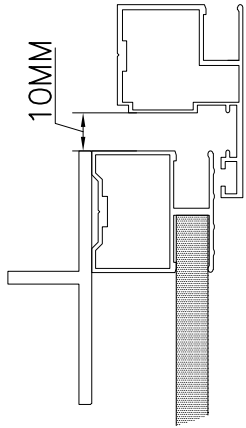
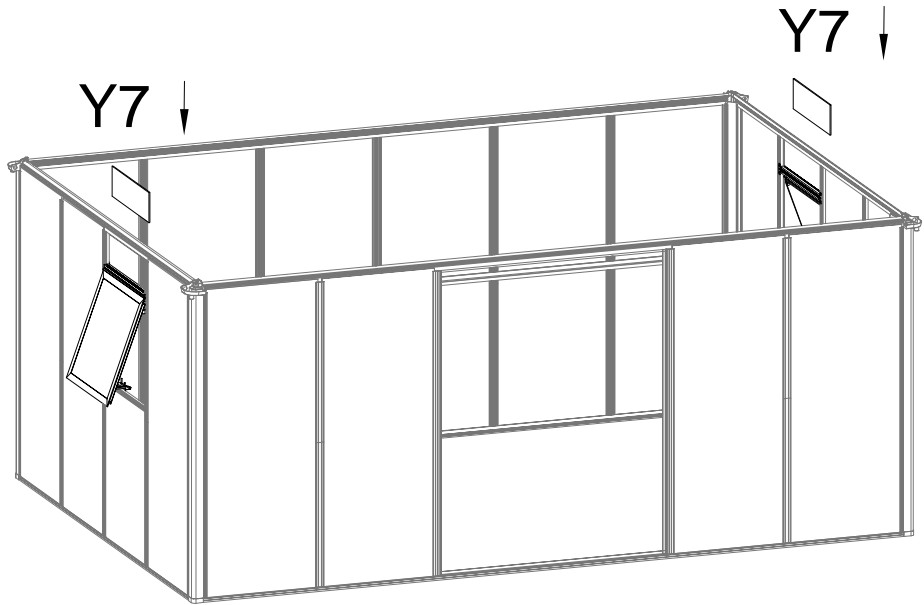

PART	NO	QTY
	WINDOW	2
	A03	2
	Y7	2
	D49	4
	S26 M5X12	4
	Z08 M4.2X16	12

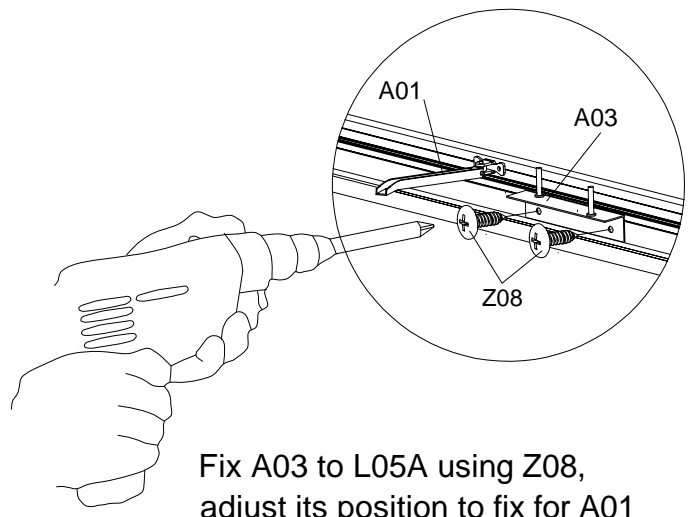
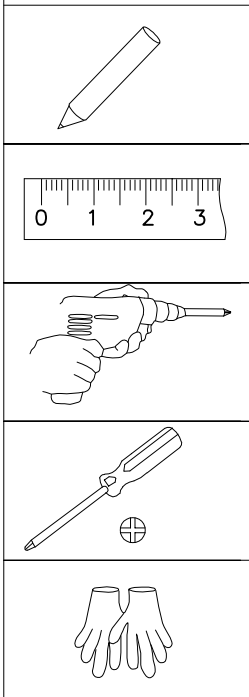

1. Fix D49 onto the window profile L11 using S26;
2. Make a mark on L03A at distance 593MM from L02E (as shown on the left). Do the same on the other end.
3. Fix the window to L03A, using Z08.
4. Insert Y7 into the channel of L03A.



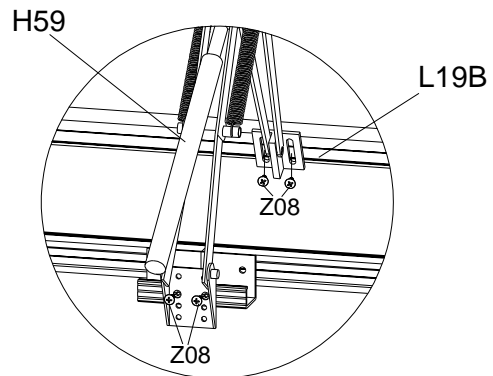
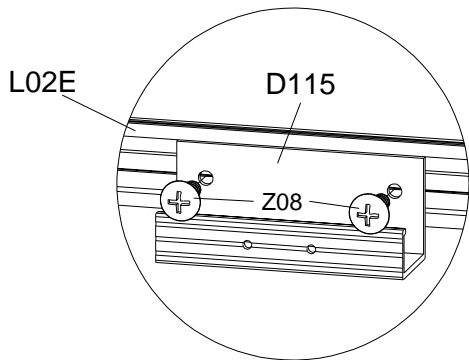
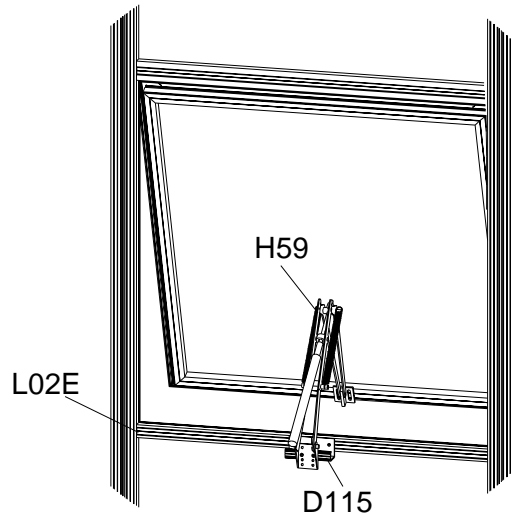

Fix A03 to L05A using Z08, adjust its position to fix for A01 before you tight up Z08.

PART	NO	QTY
	H59	1
	D115	1
	Z08	6
	M4.2X16	

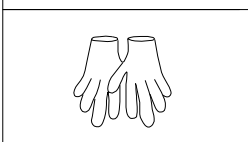
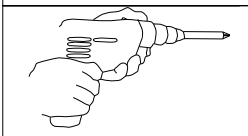

Fix D115 onto L02E, using Z08;
and fix the auto opener onto D115 and L19B (window profile),
using Z08.





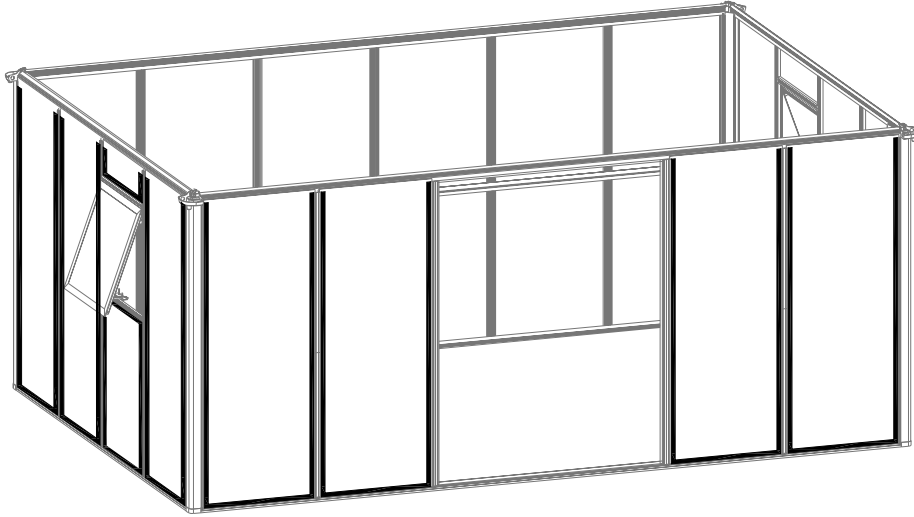

PART	NO	QTY
	J107	80M

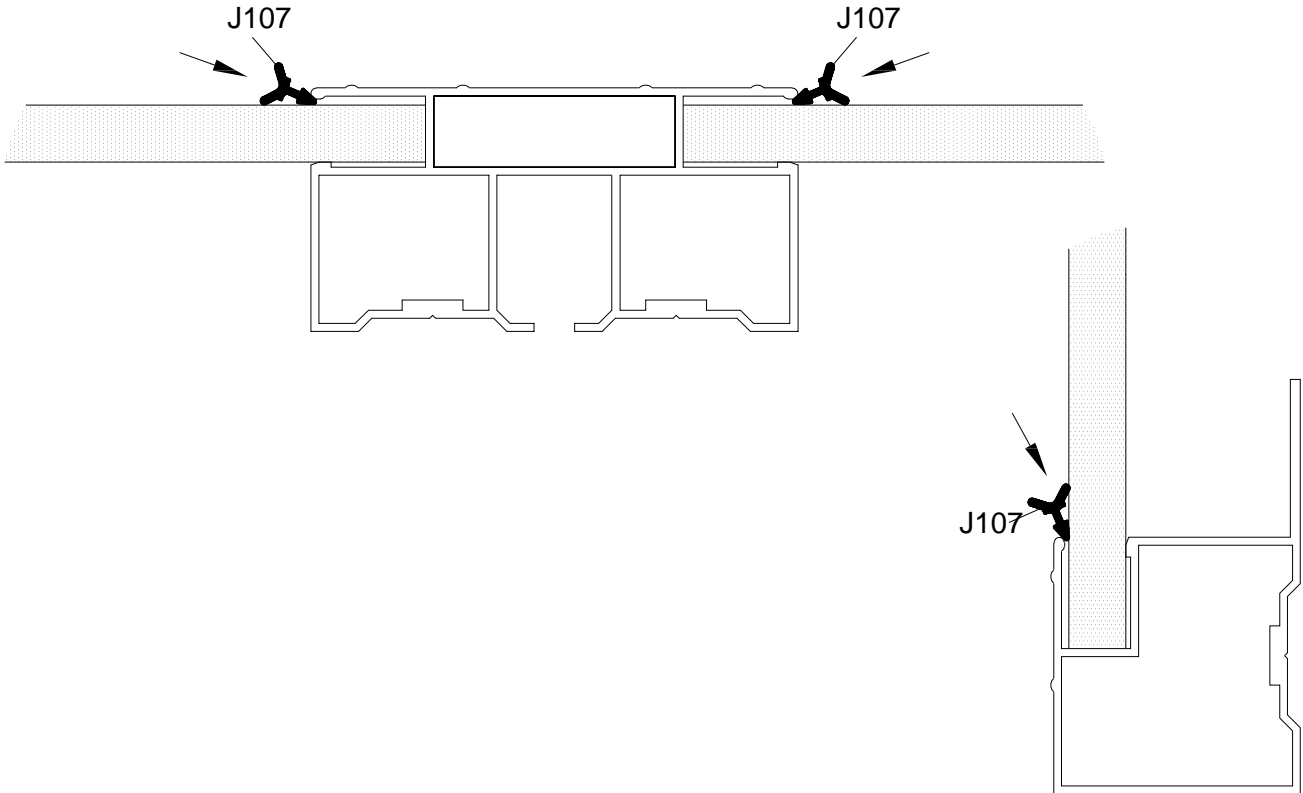

If glass is chosen, please seal it with rubber(J107) provided.



PART	NO	QTY
	L23A	4
	L03D	4
	D56	2
	D52	4
	S26 M5X12	48

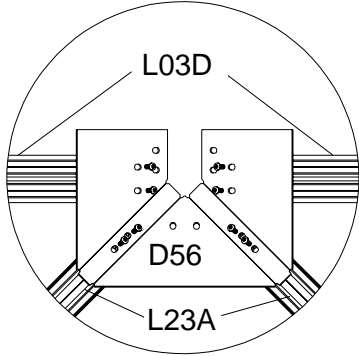
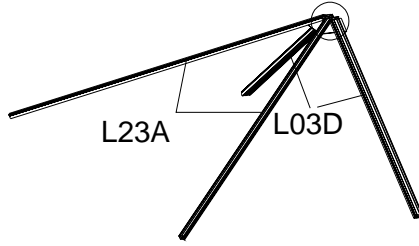

Fix L23A (2PCS) and L03D (2PCS) to D56 as shown above, using S26.

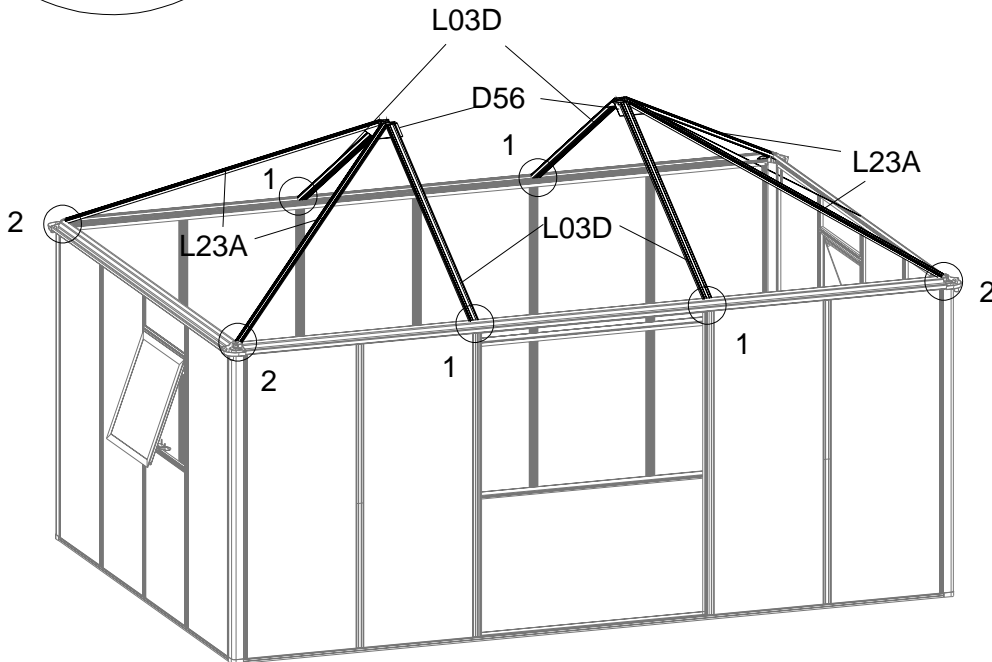





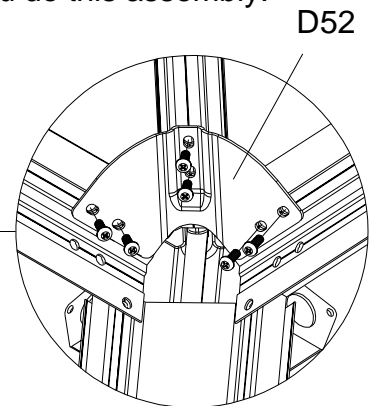
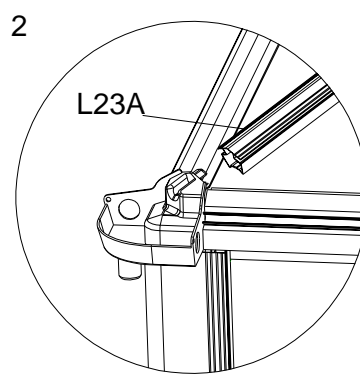
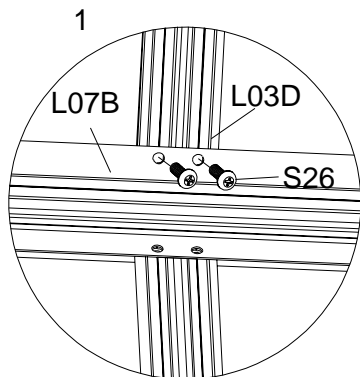
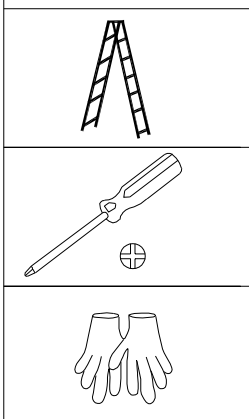

Fix the roof profiles L23A to L07A & L07B, with D52, using S26.

Fix L03D to L07A & L07B, using S26.

Note: Extra hands are needed to hold the profiles when you do this assembly.



PART	NO	QTY
	L03D	2
	L03E	2
	L06A	1
	J40	2
	M05 M5	8
	S26 M5X12	24

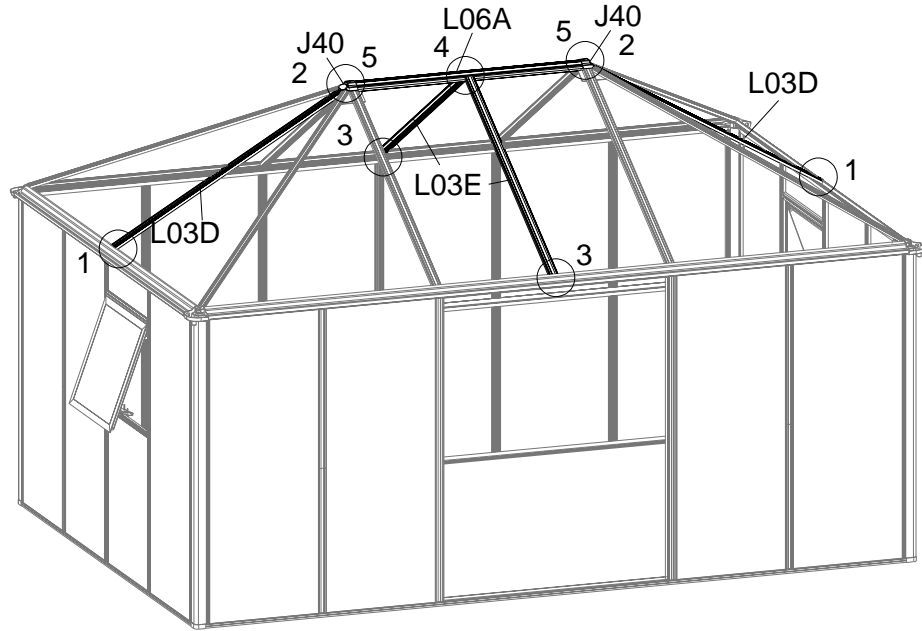



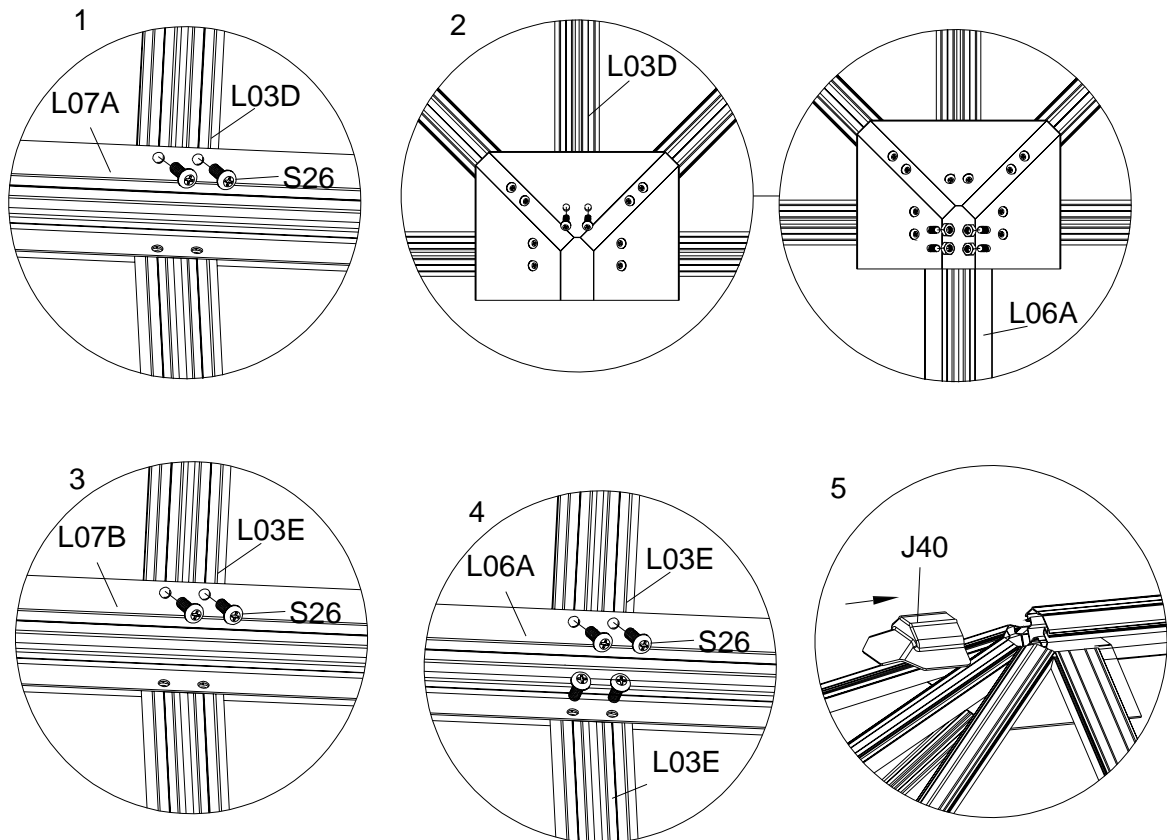



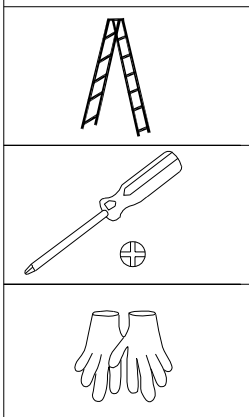





Fix L06A to L23A & L03D with J40, using S26



Fix L03E to L06A and L07A, using S26.



PART	NO	QTY
	L03B	4
	L03C	4
	L09A	2
	L09B	2
	D53	4
	Y1	4
	Y2	4
	Y3	4
	Y4	4
	Y8	4
	S26 M5X12	40

PART	NO	QTY
	J107	62M

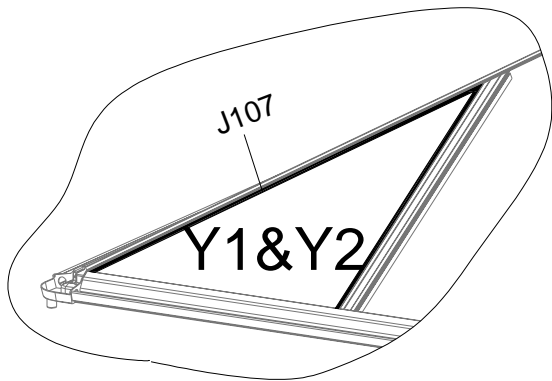
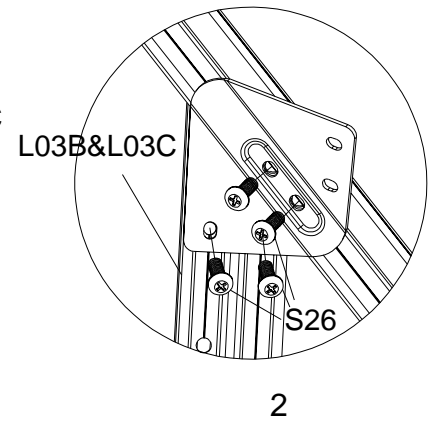
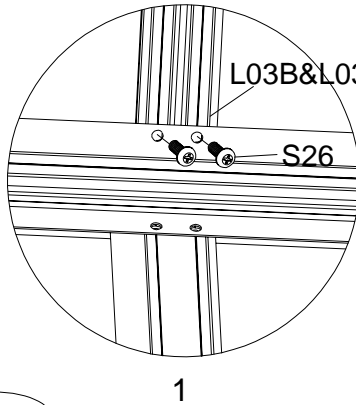
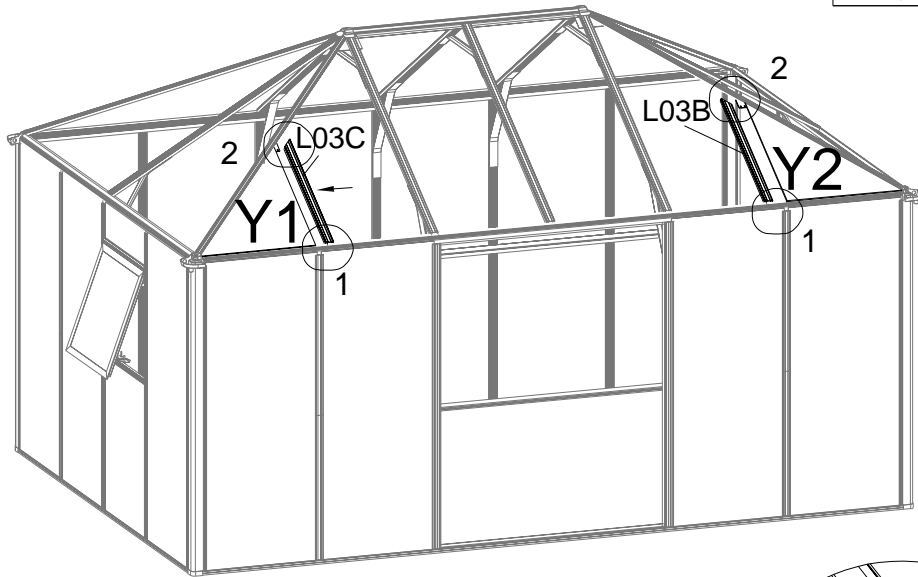

Insert Y1/Y2 into the right position before fixing L03B /L03C.

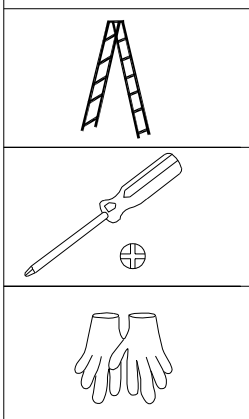
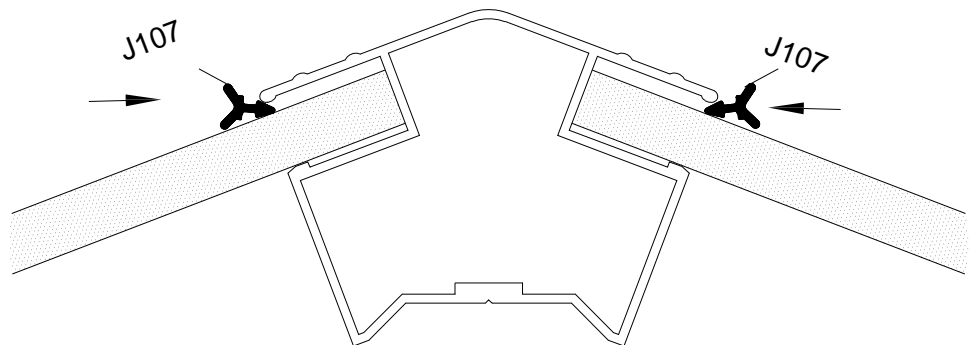

If glass is chosen, please seal it with rubber (J107) provided.
 If polycarbonate sheet is chosen, rubber is not provided.
 Please seal it with silicone sealant (not provided).

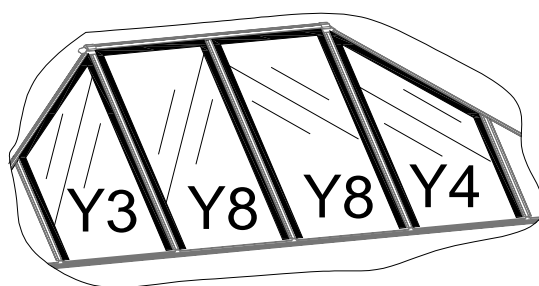
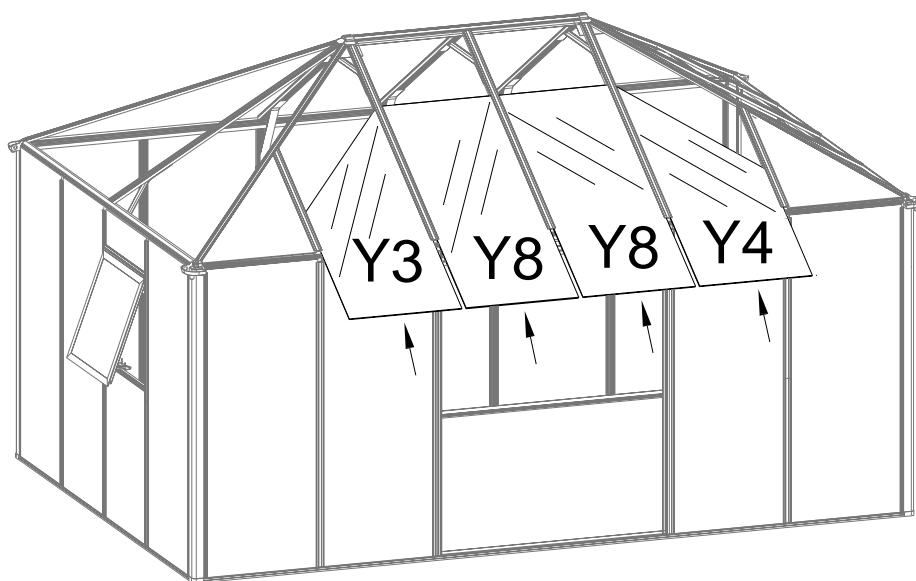

Put Y3, Y4 and Y8 into positions

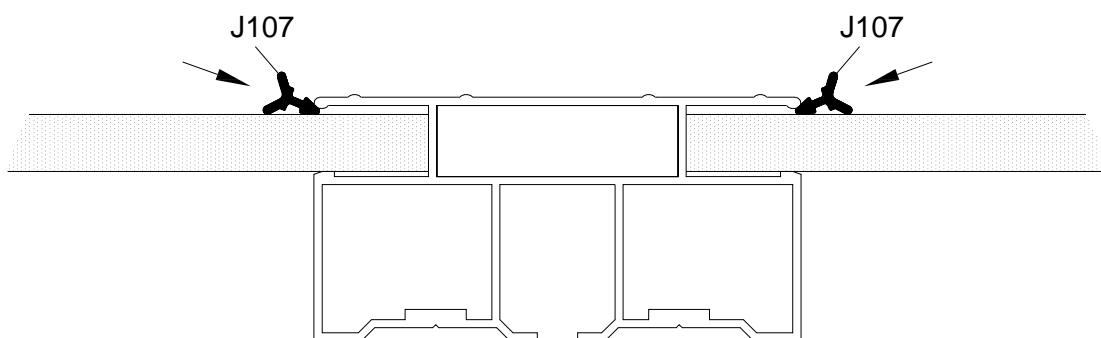

If glass is chosen, please seal it with rubber (J107) provided.
If polycarbonate sheet is chosen, rubber is not provided.
Please seal it with silicone sealant (not provided).

Gutter Assembly

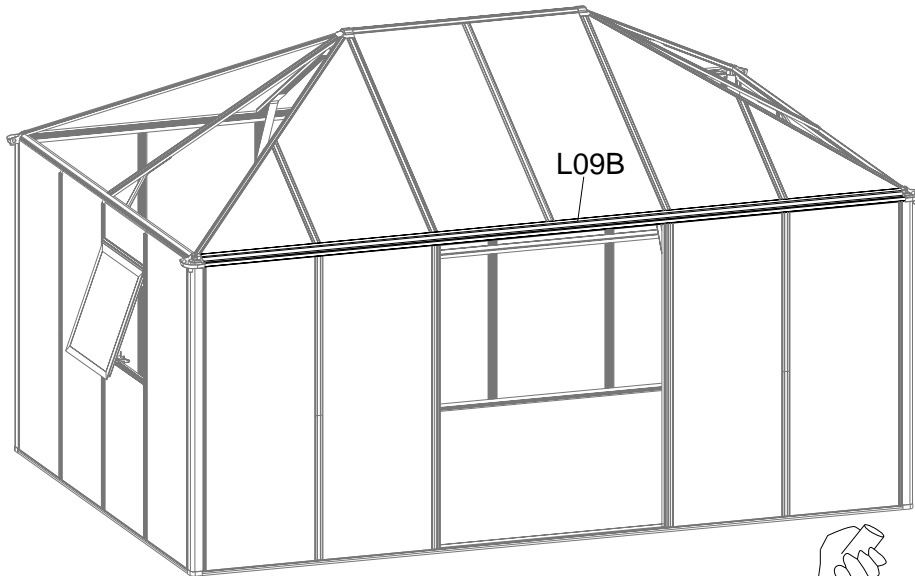

When the panels are completely inserted, fix gutter profile L09B.
Tap it gently into position with a rubber mallet.

Do the same on the other side.

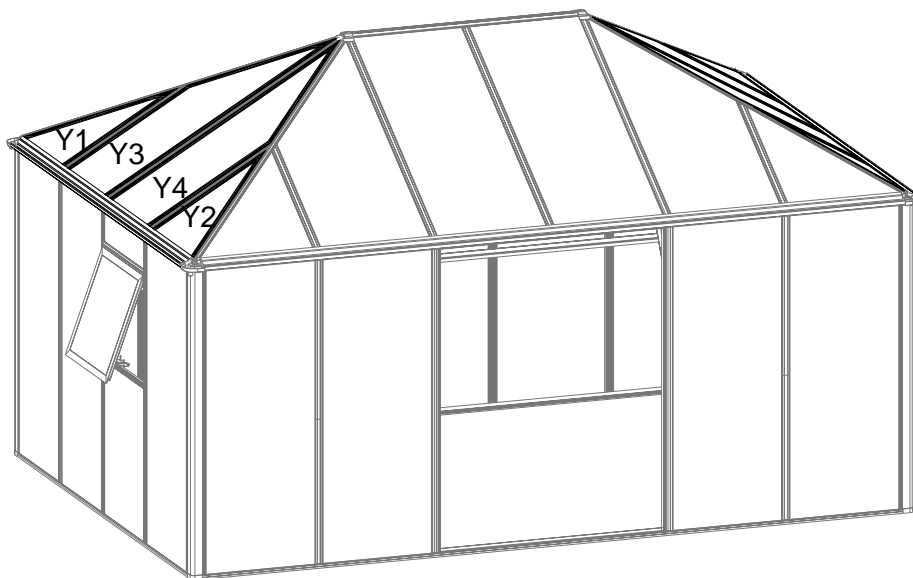
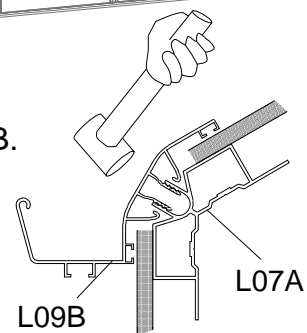





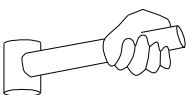

Assembly the other 2 sides.

Firstly, put Y1 & Y2 into positions, and fix L03B & L03C to L23A & L07A;

Secondly, put panel Y3 & Y4 into positions;

Finally, fix the gutter profile L09A. Tap it gently into position with a rubber mallet.



PART	NO	QTY
	L05A	2
	L05C	2
	L05E	10
	Z08 M4.2X16	112
	S26 M5X12	16

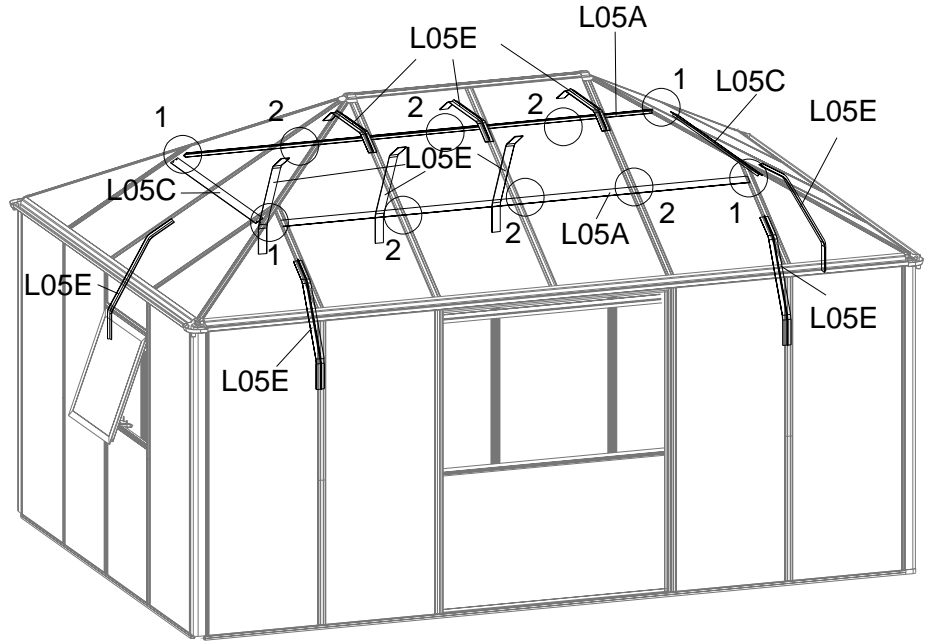

L03B&L03C

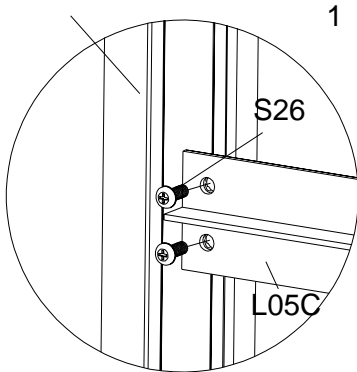

1

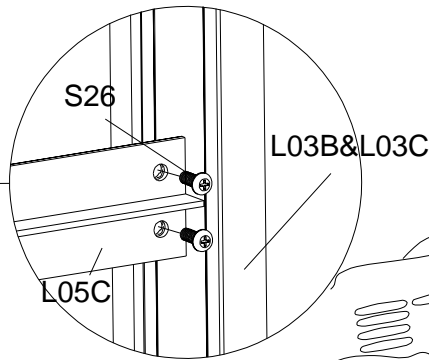

L03B&L03C

L03D

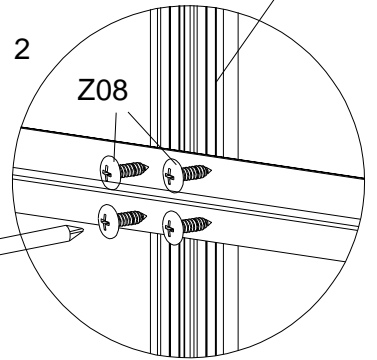



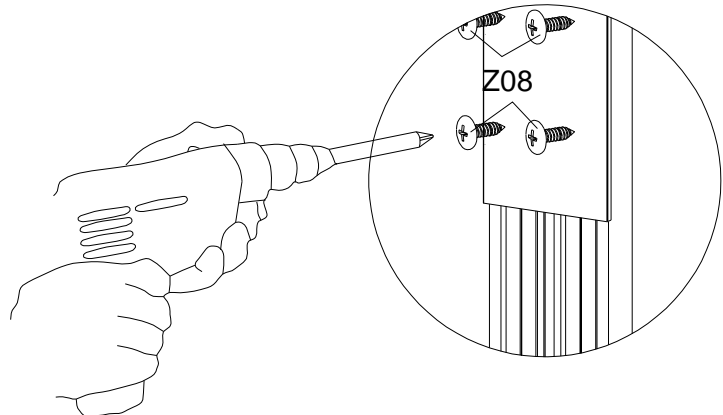
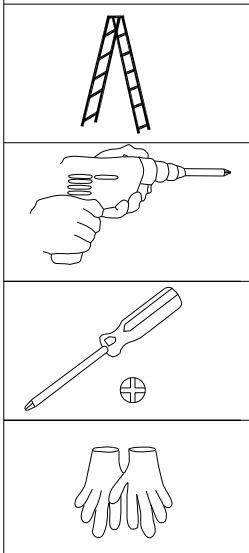
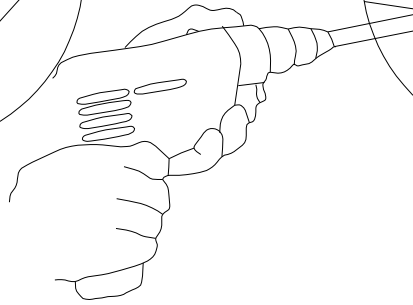

2

Fix L05A&L05C to L03B & L03C using S26,
and fix it to L03D using Z08.



Fix the eave bracing L05E using Z08 as shown.

PART	NO	QTY
	L24	1
	A51	4
	Z08 M4.2X16	3
	Z17 M4.8X16	8
	S27 M5X12	24

Door Assembly

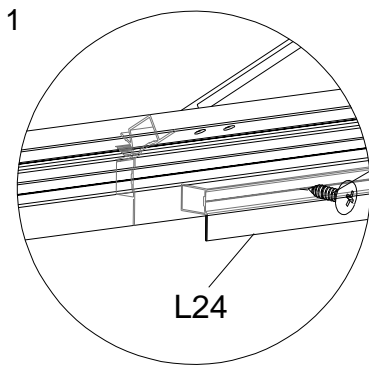
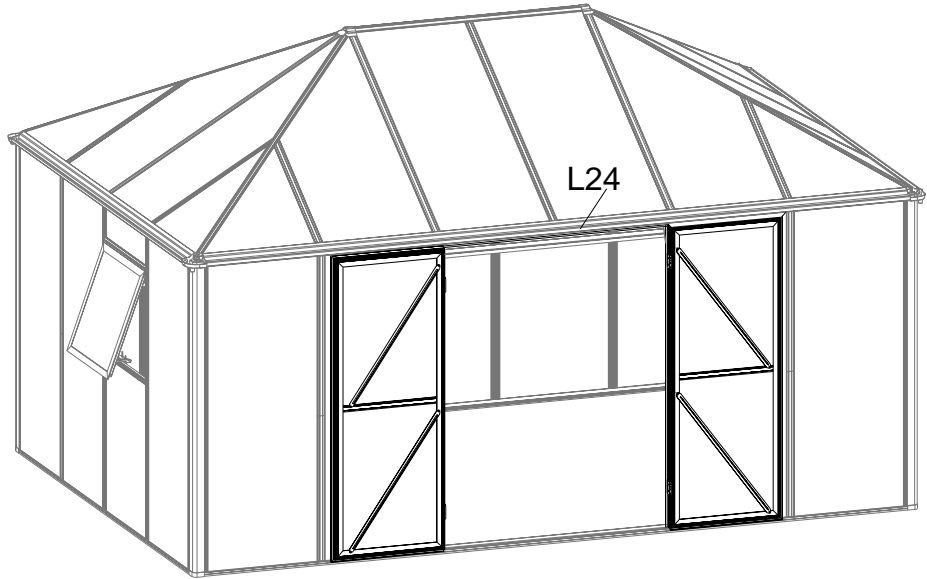

Z08

L24

Fix L24 to L07B, using Z08.

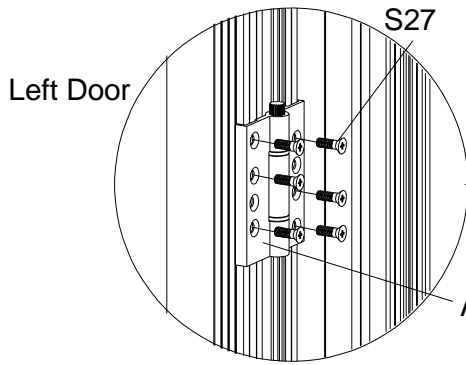

Left Door

S27

A51

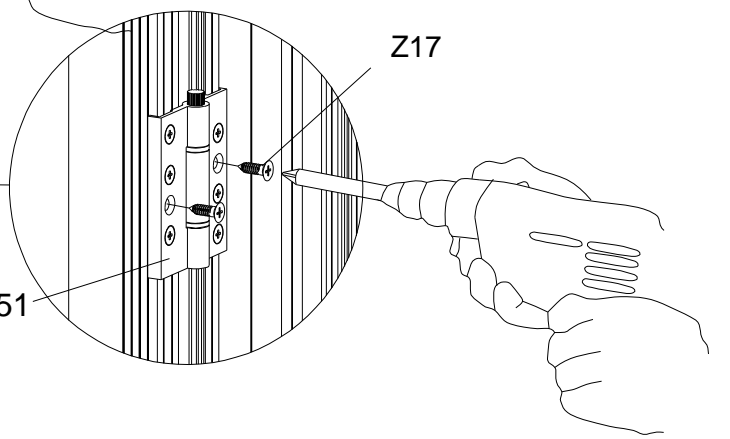

Z17

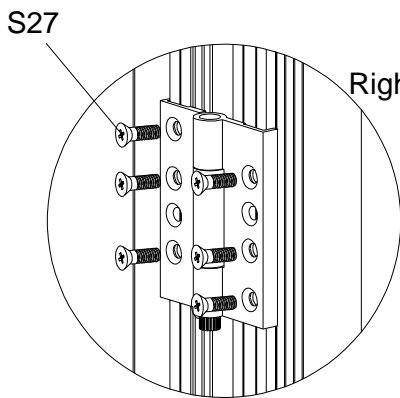

Right Door



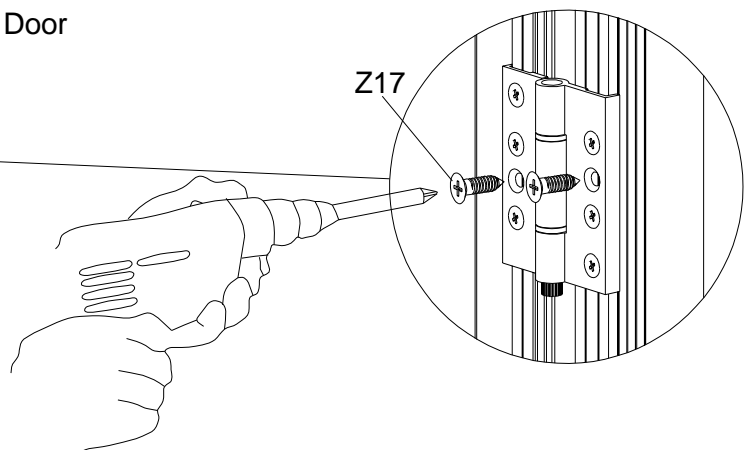

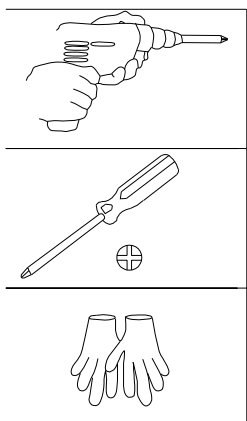

S27



Z17



Fix L25(4 PCS) one side to the door profile and the other side to L04A/L04B using S27. Then secure with Z17.

PART	NO	QTY
	L25	4
	J93	4
	J92	4
	H10	2
	Z06 Ø3.2X10	4
	Z08 M4.2X16	8

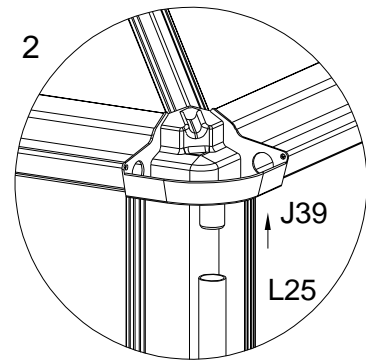
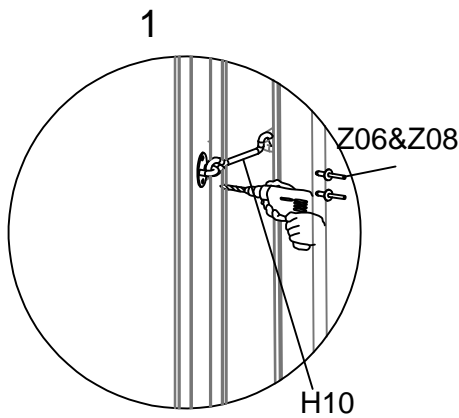
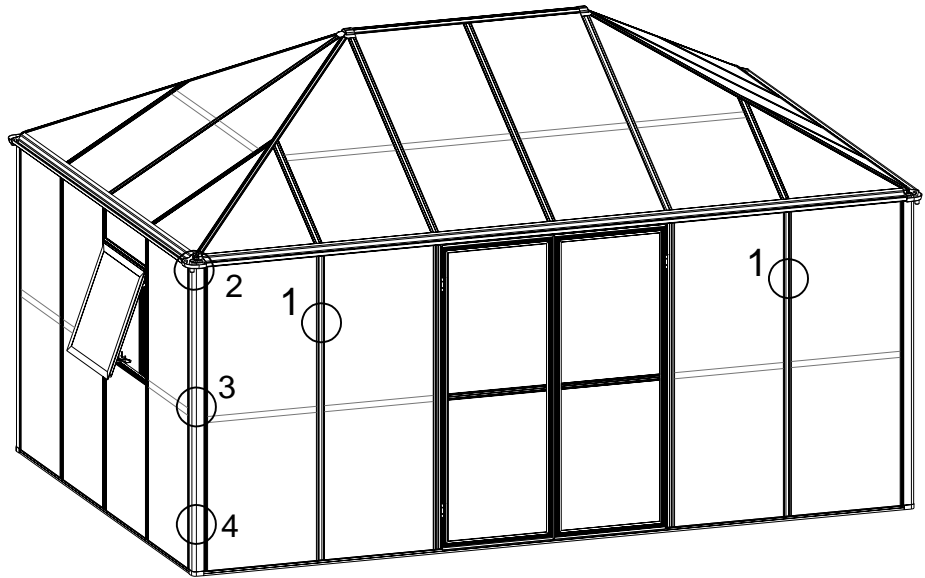

Drill the holes on each L03A as shown, Dia.3.2mm, and secure the hooks H10 with Z06 & Z08, then ensure H10 works with Door properly when the doors are open.

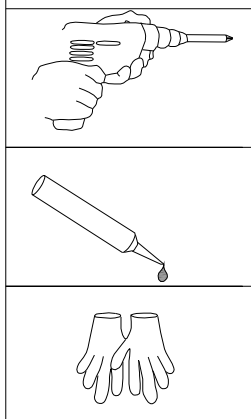
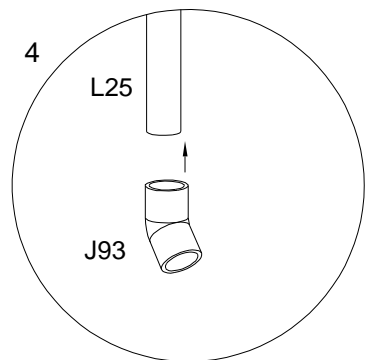
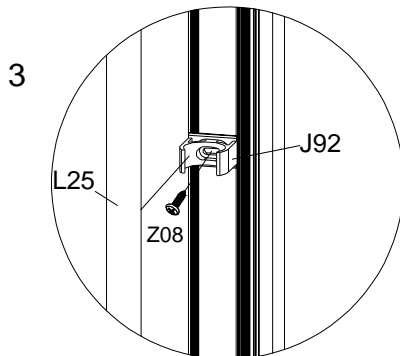

Drill a hole in L01A, approximately 3mm diameter and 700mm up from the bottom. Fix the J92 downpipe bracket with Z08 screws and then clip the L25 downpipe into the J92 bracket.

If you wish to eliminate leaks use glue when fixing the downpipe bends (not provided).

Contact information

Head office:

Dancover A/S
Lyngevej 16A, Nørre Herlev
3400 Hillerød
Denmark

For more information
please visit:
www.dancovershop.com

National contact

Denmark:

denmark@dancover.com

UK:

uk@dancover.com

Germany:

germany@dancover.com

France:

france@dancover.com

Sweden:

sverige@dancover.com

Finland:

suomi@dancover.com

Poland:

polska@dancover.com

Luxembourg:

luxembourg@dancover.com

Portugal:

portugal@dancover.com

Spain:

espana@dancover.com

Italy:

italia@dancover.com

Switzerland:

schweiz@dancover.com

Austria:

austria@dancover.com

Norway:

norge@dancover.com

Nederland:

nederland@dancover.com

Ireland:

ireland@dancover.com

Belgium:

belgique@dancover.com